

Safety Precautions

- Important Notes on exporting this product or equipment containing this product;
If the end-user or application of this product is related to military affairs or weapons, its export may be controlled by "Foreign Exchange and Foreign Trade Control Law" of Japan where export license will be required before product can be exported from Japan.
- This product is designed and manufactured for use in General Purpose Industrial Equipment and it is not intended to be used in equipment or system that may cause personal injury or death.
- All servicing such as installation, wiring, operation, maintenance and etc., should be performed by qualified personnel only.
- Tighten mounting screws with an adequate torque by taking into consideration strength of the screws and the characteristics of material to which the product will be mounted. Over tightening can damage the screw and/or material; under tightening can result in loosening.
*Example: apply 2.7 – 3.3 N·m torque when tightening steel screw (M5) to steel surface.
- Install safety equipment to prevent serious accidents or loss that is expected in case of failure of this product.
- Consult us before using this product under such special conditions and environments as nuclear energy control, aerospace, transportation, medical equipment, various safety equipments or equipments which require a lesser air contamination.
- We have been making the best effort to ensure the highest quality of our products, however, some applications with exceptionally large external noise disturbance and static electricity, or failure in input power, wiring and components may result in unexpected action. It is highly recommended that you make a fail-safe design and secure the safety in the operative range.
- If the motor shaft is not electrically grounded, it may cause an electrolytic corrosion to the bearing, depending on the condition of the machine and its mounting environment, and may result in the bearing noise. Checking and verification by customer is required.
- Failure of this product depending on its content may generate smoke of about one cigarette. Take this into consideration when the application of the machine is clean room related.
- Please be careful when using the product in an environment with high concentrations of sulfur or sulfuric gases, as sulfuration can lead to disconnection from the chip resistor or a poor contact connection.
- Do not input a supply voltage which significantly exceeds the rated range to the power supply of this product. Failure to heed this caution may lead to damage of the internal parts, causing smoke and/or fire and other troubles.
- The user is responsible for matching between machine and components in terms of configuration, dimensions, life expectancy, characteristics, when installing the machine or changing specification of the machine. The user is also responsible for complying with applicable laws and regulations.
- Manufacturer's warranty will be invalid if the product has been used outside its stated specifications.
- Component parts are subject to minor change to improve performance.
- Read and observe the instruction manual to ensure correct use of the product.

Repair

Consult to the dealer from whom you have purchased this product for details of repair work.
When the product is incorporated to the machine you have purchased, consult to the machine manufacturer or its dealer.

URL

Electric data of this product (Instruction Manual, CAD data) can be download from the following web site;
<http://industrial.panasonic.com/ww/i_e/25000/motor_fa_e/motor_fa_e.html>

Contact :



Panasonic Corporation,
Appliances Company,
Motor Business Division

1-1 Morofuku 7-chome, Daito, Osaka 574-0044, Japan
Tel : +81-72-871-1212
Fax: +81-72-870-3151

The contents of this catalog apply
to the products as of March 2014.

Network, Linear & Direct Drive Motor Control System Collaboration

Panasonic Corporation, Appliances Company, Motor Business Division
http://industrial.panasonic.com/ww/i_e/25000/motor_fa_e/motor_fa_e.html

Servo motor that brings out potential of the machine.

Linear and DD motor control type

A5L series

Special Order Product



- Position, Speed, Thrust control
- Drastically reduced setup time by automatic setup
- Automatic magnetic pole detection function will detect the magnetic pole position of the linear motor.

“Realtime Express” model

Ultra high-speed Network type

A5N series

Special Order Product



- Synchronized motion and precise CP control up to 32 axes with 100 Mbps communication
- Standard Ethernet cable*1 using

DC 24 V type

A5MN series

Special Order Product

Coming soon



- Rated output:
10 W, 20 W, 30 W
- Synchronized motion and precise CP control up to 32 axes with 100 Mbps communication
 - Standard Ethernet cable*1 using

RS485 communication AE-LINK type

A5A series

Special Order Product



- Positioning is possible by built-in NC function
- Can connect up to 31 axes
- Standard Ethernet cable*1 using
- Two-degree-of-freedom control

* AE-LINK is a registered trade mark of Asahi Engineering.

Linear and DD motor control type

A5NL series

Special Order Product



- Position, Speed and Thrust controls can be done by using the “Realtime Express”
- Drastically reduced setup time by automatic setup
- Automatic magnetic pole detection function will detect the magnetic pole position of the linear motor.

Linear motor control, DC 24 V type

A5MNL series

Special Order Product

Coming soon

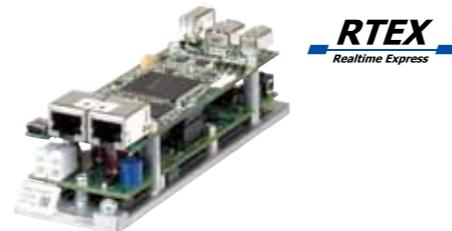

- Capacity of applying Linear motor:
Compatible with 30 W rotary AC servo motor
- Position, Speed and Thrust controls can be done by using the “Realtime Express”
 - Drastically reduced setup time by automatic setup

[Special Order Product] : For details, see the website or request for information. *1 Shielded twisted pair cable (CAT5e or higher)

[Partner product] (Quality of partner product is guaranteed by the manufacturer and distributor.)

RTEX (Applicable product : A5N / A5NL / A5MNL series)

Introduction of MINAS A5N series and RTEX	3
AJINEXTEK CO., LTD.	5
Asahi Engineering Co., Ltd.	7
Aurotek Corporation	9
Delta Tau Data Systems, inc.	11
Panasonic Industrial Devices SUNX Co., Ltd.	13
Prime Motion Inc.	15
Shanghai Bitpass Automation Technology Development Co., Ltd	17
SOFT SERVO SYSTEMS, INC.	21
TIETECH Co., Ltd.	23
Trio Motion Technology Ltd.	27
Vanguard Systems Inc.	29
Anywire Corporation	31
RTEX corresponding table and ASIC information	32

AE-LINK (Applicable Product : A5A / A5AL series)

Introduction of MINAS A5A series and AE-LINK	33
Asahi Engineering Co., Ltd	35

LINEAR MOTOR and DIRECT DRIVE MOTOR (Applicable Product : A5L / A5NL / A5AL / A5MNL series)

Introduction of MINAS A5L series	37
Akribis Systems Pte Ltd	39
Justek Inc.	43
Nippon Bearing Co., Ltd.	45
Nippon Pulse Motor Co., Ltd.	47
MIRAE Linear Motor Technology	51
Sodick Co., Ltd.	53

FEED BACK SCALE (Applicable Product : All Products)

FAGOR AUTOMATION	55
GSI Group Japan Corporation	57
Magnescale Co., Ltd.	58
Mitutoyo Corporation	59
NIDEC SANKYO CORPORATION	60
Renishaw plc	61
Feed back scale selection	62

ACTUATOR (Applicable Product : A5, A5N)

Harmonic Drive Systems Inc.	63
------------------------------------	----

Ultra High-Speed Network Servo MINAS A5N series



Realtime Express (RTEX)

Ultimate Real-time performance

- Velocity response **2300 Hz**
- Com. speed **100 Mbps Full-duplex**
- Com. period min. **0.083 ms** Below 0.1 ms!

Functionality to meet various needs

- Pos./Vel./Torq. all modes
- Accurate position latch
- IEC safety I/F model available ^{*1}

Simple network

- High-performance & Low-cost
- Isochronous established by ASIC
- Easy device development



MINAS A5 Performance + **Extended Protocol**

[Typical system configuration]

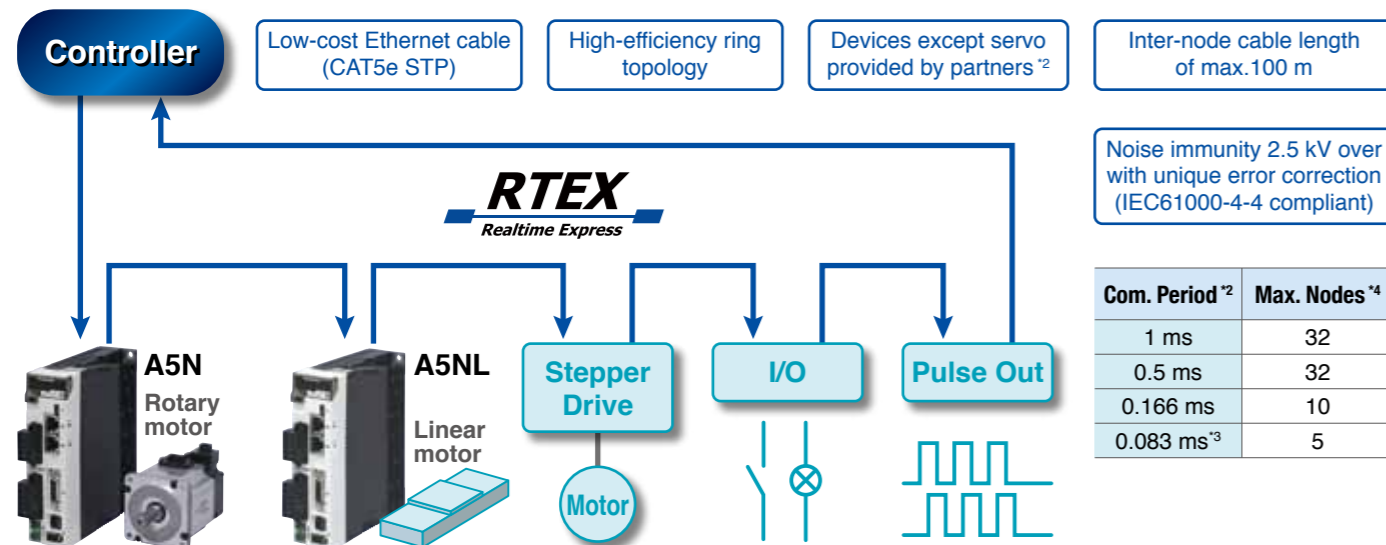

^{*1}: Special model. IEC61800-5-2 STO, IEC61508 SIL2. ^{*2}: The communication period and connection of slave devices depend on the controller specification. ^{*3}: For communication period 0.083 ms, command update period is 0.166ms only. ^{*4}: Slave nodes.

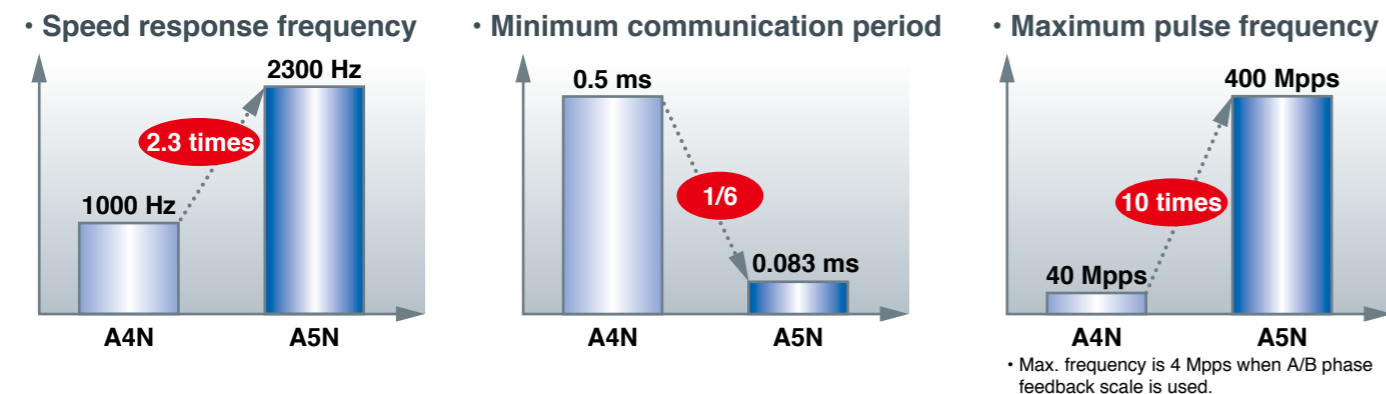

Drive list

Drive power supply	Motor rated output										
	50 W	100 W	200 W	400 W	750 W	1 k to 1.5 kW	2 kW	3 kW	4 k to 5 kW	7.5 kW	11 k to 15 kW
Single phase 100 to 120 VAC	A	A	B	C							
	MADH T1105 NA1	MADH T1107 NA1	MBDH T2110 NA1	MCDH T3120 NA1							
Single/3-phase 200 to 240 VAC	A	A	B	C	D						
	MADH T1505 NA1	MADH T1507 NA1	MBDH T2510 NA1	MCDH T3520 NA1	MDDH T5540 NA1						
3-phase 200 to 230 VAC						E	F	F	G	H	
						MEDH T7364 NA1	MFDH TA390 NA1	MFDH TB3A2 NA1	MGDH TC3B4 NA1	MHDH TC3B4 NA1	
3-phase 380 to 480 VAC					D	D	E	F	F	G	H
					MDDH T2412 NA1	MDDH T3420 NA1	MEDH T4430 NA1	MFDH T5440 NA1	MFDH TA464 NA1	MGDH TB4A2 NA1	MHDH TB4A2 NA1

Upper line: Frame size symbol Lower line: Typical model No.

- Some motors do not match model numbers in the table. Check correct combination in the A5 family catalog.
- Trailing NA1 in the part number for product with safety I/F option is replaced with N01.

Appearance

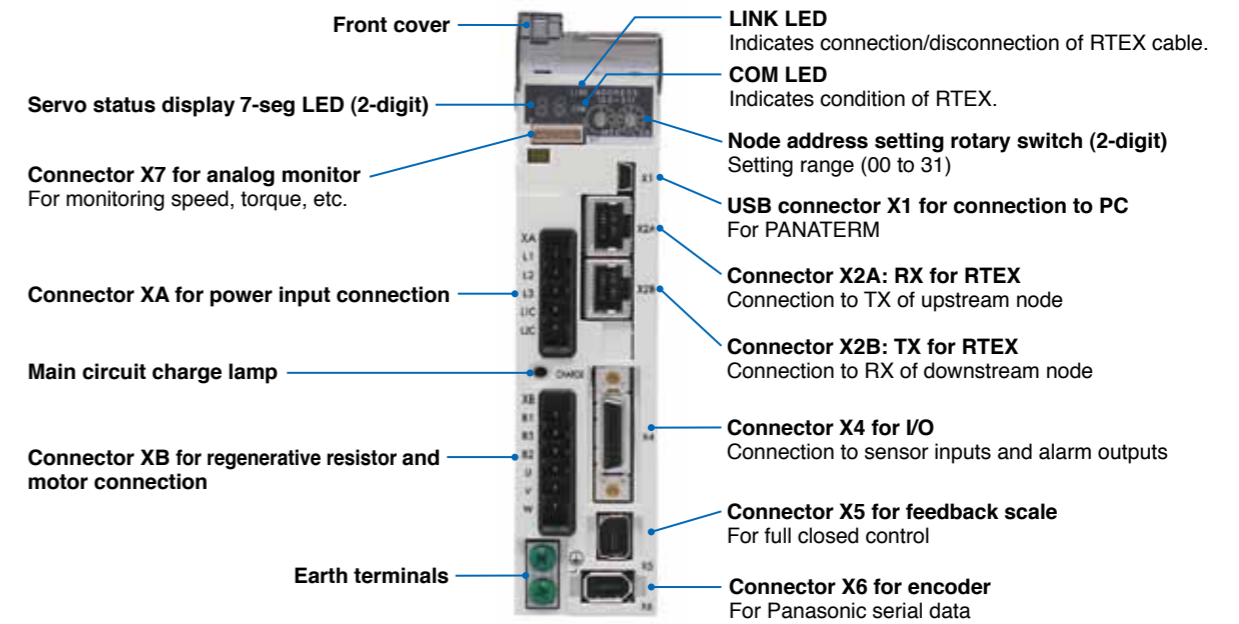

Dimensions (mm): W40 x H150 x D135 (A-frame)

Applicable standards



RTEX Master Board

PCI-R1604

Features

- RTEX network Master Board
- Network Speed 100 Mbps, Communication Period 0.5 ms
- Support RTEX Standard Servo Profile, Standard I/O Profile
- Basic configuration is 16 axes control (Can be expanded to 20,24,28, and 32 axes)
- Easy to wire, saving wiring working-hour
- Max. 32 nodes
- Network connection - 100 BASE-TX, STP Cable (above CAT5e)
- Excellent Error correction
- Multi-axes linear / circular interpolation
- Limit setting functions : soft stop, emergency stop, and two positions



Specification

Item	Description
RTEX Master Board	
Max. number of nodes	32
Max. ring loop length	200 m
Max. node to node length	60 m
Connector / cable type	RJ45 RX/TX, STP (Shielding type)
Power supply / current consumption	5 V _{DC} / 1.0 A
Position range	32-bit (±2147483648)
Motion	
Interpolation	Max. 32 synchronized drive, 2 to 4 axes linear interpolation, and 2 axes arc interpolation,
Gantry motion	Max. 32 slave axes can follow the master axis to move synchronously

Item	Description
Software	
User Agent Software	EzSoftware RM
Operating System	Windows 7 (32-bit, 64-bit) Windows XP (32-bit, 64-bit)
General specification	
Dimension	174.63 mm × 106.00 mm
Weight	120 g (Expend 32axes-161 g)
Operation temperature	0 °C to 60 °C

Application Sample

- Semiconductor front/back end process field
- Solar Energy/FPD/PCB field
- Processing machine field

Please contact the following address for details

URL : <http://www.ajinextek.com/ENG/menu04/page01.php>

System Configuration

RTEX Based Motion Network

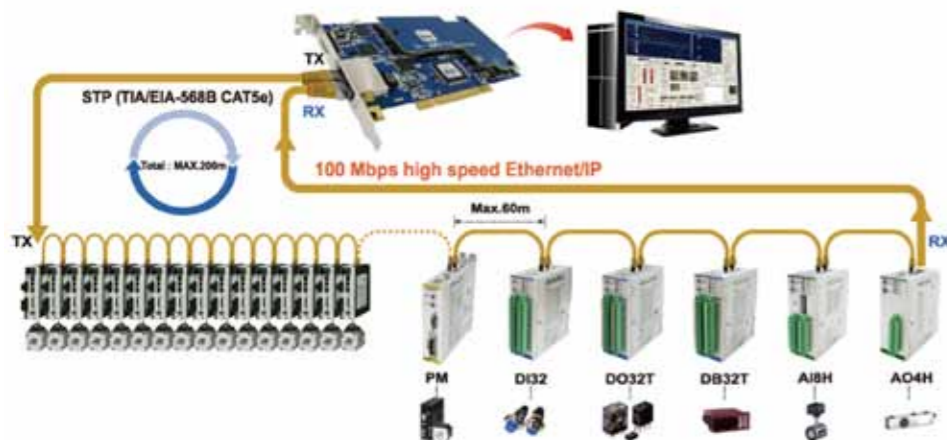

Master Board	PCI-RXX04
Motion Module	RTEX-PM
DIO Module	RTEX-DI32
	RTEX-DB32T
AIO Module	RTEX-AI8H
	RTEX-AO4H

Motion Function Module — RTEX-PM

Item	Description
RTEX-PM	
Module function	RTEX based 1axis of slave motion function module
NODE ID setting	Decimal number rotary switch × 2 (0 to 31)
Mounting Method	Standard 35 mm DIN rail mounting
Power supply / current consumption	24 V _{DC} / 200 mA (Connected to TB1 outside the module, without external I/O power)
LED display	Power (Yellow), Live (Green), Error (Red), Com (Yellow)
Pulse output	PULSE+, PULSE-, DIR+, DIR- LINE TRANSMITTER (5 V _{DC} , MAX. 13MPPS)
Encoder input	ENC-A, /A, B, /B, Z, /Z : High-speed Photo-coupler (5 V _{DC} , MAX. 8 MPPS) ENCPWR, DGND : 5 V _{DC} output (when using the encoder for step motors)
Motion control Input / Output	ALARM, INP, RDY (IN4) : Photo-coupler (24 V _{DC} Level) SVON, ALMC, DCC, TRG (*) : Dallington Photo-coupler (24 V _{DC} Level) LIMIT+, LIMIT-, ORG : Photo-coupler (24 V _{DC} Level) TRG+, TRG- : Line Transmitter (5 V _{DC} Level) BRK (OUT4) : Photo-coupler + Drive IC (24 V _{DC} Level) PCOM, NCOM : Digital I/O Positive and Negative Common Motion Connector : Honda 26 pin X 1 EA Motion I/O Connector : 3M 26 pin X 1 EA
Universal input	IN2, IN3 : Photo-coupler (24 V _{DC} Level)
Universal output	OUT2, OUT3 : Photo-coupler + Drive IC (24 V _{DC} Level)
Software	
User Agent Software	EzSoftware RM
Operating System	Windows 7 (32-bit, 64-bit), Windows XP (32-bit, 64-bit)
General specification	
Dimension (HxDxW)	120 mm × 110 mm × 25 mm
Weight	192 g
Operation temperature	0 °C to 60 °C

Digital Input Function Module — RTEX-DI32

Item	Description
RTEX-DI32	
Module function	RTEX based slave 32ch digital input function module
NODE ID setting	Decimal number rotary switch × 2 (0 to 31)
Mounting Method	Standard 35 mm DIN rail mounting
Power supply / current consumption	24 V _{DC} / Max. 500 mA (TB1 Connection to Outside Module)
LED display	Power (Yellow), Live (Green), Error (Red), Com (Yellow) IN1 to IN32 (Yellow)
Digital input	Input 32 channels, 24 V _{DC} Level IN1 to IN32 : Photo-coupler isolation (More over MIN. 2 mA/ch) PCOM, NCOM : Digital I/O Positive and Negative Common Connector : Phoenix 16 X 2 (MCD 1,5/16-GIF-3,81)
Software	
User Agent Software	EzSoftware RM
Operating System	Windows 7 (32-bit, 64-bit), Windows XP (32-bit, 64-bit)
General specification	
Dimension (HxDxW)	100 mm × 90 mm × 40 mm
Weight	245 g
Operation temperature	0 °C to 60 °C

Analog Input Function Module — RTEX-AI8H

Item	Description
RTEX-AI8H	
Module function	RTEX based slave 8ch analog input function module
NODE ID setting	Decimal number rotary switch × 2 (0 to 31)
Mounting Method	Standard 35 mm DIN rail mounting
Power supply / current consumption	24 V _{DC} / Max. 500 mA (TB1 Connection to Outside Module)
LED display	Power (Yellow), Live (Green), Error (Red), Com (Yellow)
Number of input channels	8 channels
Resolution	16-bit
Analog input	Input 8 channel Voltage mode : -10 V to +10 V, Electric current mode : 4 mA to 20 mA (control the switch) Resolution : 16-bit Sampling speed : 100 kHz Connector : Phoenix 10 X 2 (MCD 1,5/20-G1F-3,81)
Software	
User Agent Software	EzSoftware RM
Operating System	Windows 7 (32-bit, 64-bit), Windows XP (32-bit, 64-bit)
General specification	
Dimension (HxDxW)	100 mm × 90 mm × 40 mm
Weight	244 g
Operation temperature	0 °C to 60 °C

Digital Input/Output Function Module — RTEX-DB32T

Item	Description
RTEX-DB32T	
Module function	RTEX based slave 16ch digital input & 16ch digital output function module
NODE ID setting	Decimal number rotary switch × 2 (0 to 31)
Mounting Method	Standard 35 mm DIN rail mounting
Power supply / current consumption	24 V _{DC} / Max. 500 mA (TB1 Connection to Outside Module)
LED display	Power (Yellow), Live (Green), Error (Red), Com (Yellow) IN1 to IN16 (Yellow) OUT1 to OUT16 (Red)
Digital input/output	32 channels, 24 V _{DC} Level (16ch Input / 16ch Output) IN1 to IN16 : Photo-coupler isolation (More over MIN. 2 mA/ch) OUT1 to OUT16 : Photo-coupler isolation (Below MAX. 50 mA/channel) PCOM, NCOM : Digital I/O Positive and Negative Common Connector : Phoenix 16 X 2 (MCD 1,5/16-GIF-3,81)
Software	
User Agent Software	EzSoftware RM
Operating System	Windows 7 (32-bit, 64-bit), Windows XP (32-bit, 64-bit)
General specification	
Dimension (HxDxW)	100 mm × 90 mm × 40 mm
Weight	245 g
Operation temperature	0 °C to 60 °C

Digital Output Function Module — RTEX-DO32T

Item	Description
RTEX-DO32T	
Module function	RTEX based slave 32ch digital output function module
NODE ID setting	Decimal number rotary switch × 2 (0 to 31)
Mounting Method	Standard 35 mm DIN rail mounting
Power supply / current consumption	24 V _{DC} / Max. 500 mA (TB1 Connection to Outside Module)
LED display	Power (Yellow), Live (Green), Error (Red), Com (Yellow) OUT1 to OUT32 (Red)
Digital input	Output 32 channels, 24 V _{DC} Level OUT1 to OUT32 : Photo-coupler isolation (Below MAX. 50 mA/channel) PCOM, NCOM : Digital I/O Positive and Negative Common Connector : Phoenix 16 X 2 (MCD 1,5/16-GIF-3,81)
Software	
User Agent Software	EzSoftware RM
Operating System	Windows 7 (32-bit, 64-bit), Windows XP (32-bit, 64-bit)
General specification	
Dimension (HxDxW)	100 mm × 90 mm × 40 mm
Weight	245 g
Operation temperature	0 °C to 60 °C

Analog Output Function Module — RTEX-AO4H

Item	Description
RTEX-AO4H	
Module function	RTEX based slave 4ch analog output function module
NODE ID setting	Decimal number rotary switch × 2 (0 to 31)
Mounting Method	Standard 35 mm DIN rail mounting
Power supply / current consumption	24 V _{DC} / Max. 500 mA (TB1 Connection to Outside Module)
LED display	Power (Yellow), Live (Green), Error (Red), Com (Yellow)
Number of output channels	4 channels
Resolution	16-bit
Analog output	Output 4 channel Voltage mode : -10 V to +10 V Resolution : 16-bit Sampling speed : 100 kHz Connector : Phoenix 10 X 1 (MCD 1,5/10-G1F-3,81)
Software	
User Agent Software	EzSoftware RM
Operating System	Windows 7 (32-bit, 64-bit), Windows XP (32-bit, 64-bit)
General specification	
Dimension (HxDxW)	100 mm × 90 mm × 40 mm
Weight	246 g
Operation temperature	0 °C to 60 °C

Sales area and Language



- Korean
- Chinese
- English

Please contact the following address for details.

For more information

URL : <http://www.ajinextek.com/ENG/>

Contact: **AJINEXTEK CO., LTD.**

9-3, Horim-dong, Dalseo-gu, Daegu-city, Korea

[E-mail: marketing@ajinextek.com]

TEL: +82-53-593-3700 FAX: +82-53-593-3703

PLC Direct Access RTEX Motion Controller

PI-2300

Features

Building a leading edge high speed motion network at low cost under PLC

● Direct PLC access

- The controller runs the motion program installed in PI while accessing PLC data register.
- Preparation of ladder program for communication is not required on PLC.
- No CPU burden on PLC.

● Simple motion control through data register

- Motor can be controlled by operating PLC data register.
- Multiaxial motor can be controlled/monitored by simply operating numeric values on the data register.
- PLC operator having no knowledge on communication of motion (RTEX) can control the motor.

● Stepping motor can be mixed

- The motion network can contain servo motor and stepping motor.
- Ultra high-speed fully-synchronized motion system can be built.



Specification

Item	Description
Power supply	24 V _{DC} ±10 % 300 mA MAX
Operating temperature and humidity	0 °C to 50 °C, 90 %RH max. (no dewing)
Outline dimensions (mm)	W24.5 × D105 × H160
Communication with PLC	Ethernet 10/100 BASE-T Conforms to MC protocol
Setting tool	PI Assistance (complimentary)
Control signal I/O	Initialization input, system alarm output and node alarm output
Motion network	RTEX command updating period: 1 ms
No. of connection nodes	Max. 16
Motion control	Positioning and synchronized operation

2-phase Microstep Drive

D4610

Features

Leading Edge High Speed Motion Network (RTEX) At Low Cost

● High performance CPU enhances drive capability

- Step-out detection
- Triangle drive prevention
- Motor over current protection
- Vibration suppression
- Brake control
- Closed loop control by encoder signal

● RTEX in motion network

● Network can connect up to 32 axes (depending on master specification)

● Simultaneous multiaxial control within 1 ms communication period



Specification

Item	Description	
Power supply	Main power supply: 24 V _{DC} ±10 % (4.0 A max.) Sensor power supply: 24 V _{DC} ±10 % (0.1 A)	
Applicable motor	2.55 A/phase or less 2-phase HB type stepping motor	
Driving capacity	2.55 A/phase	
Micro step resolution	Basic step divided by 200 (for 40000 p/r basic step 1.8 deg motor)	
Communication specification	Realtime Express (RTEX)	
Input signal	Sensor input 4 (HOME, EX, CWLS, CCWLS), encoder input and stop input	
Output signal	Brake output and alarm output	
Protective function	Over current, power supply voltage monitoring and step-out detection	
Environment	Ambient temperature	0 °C to 50 °C (no freezing), Storage: -20 °C to 60 °C (no freezing)
	Ambient humidity	90 %RH max. (no dewing). Storage: 90 %RH max. (no dewing)
	Atmosphere	Indoor (no direct sunshine). No corrosive gas, flammable gas, oil mist, dust, etc.
	Altitude	Max. 1000 m above sea level
	Operating vibration (shock) environment	Max. 2 G (10 Hz to 250 Hz, in X,Y,Z direction 1 hour), max. 10 G (Ones)
Outline dimensions (mm)	160 × 92 × 29	
Mass	Approx. 300 g	

Application Sample

This controller is suitable for semiconductor manufacturing equipment, machine tools, measuring machines, and other machinery.

System Configuration

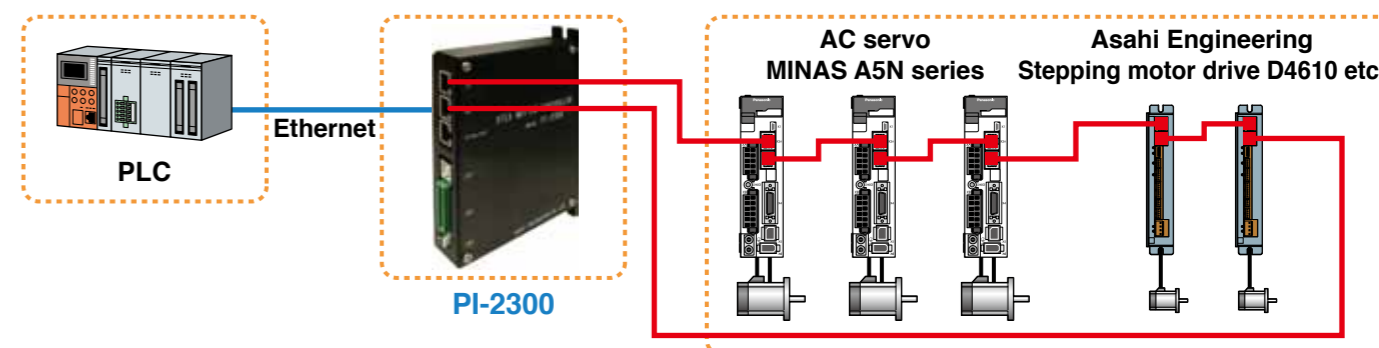

- (1) Accessing PLC data register from PI-2300 over Ethernet
- (2) Based on the contents of data register, the PI sends command to each axis (motor operation).
- (3) The PI writes status information of each axis to data register.

Sales area and Language



- Japanese
- English

Only Japanese is used for inquiry over the phone.

When making an inquiry in English, please send it to the following address.

For more information

URL : <http://www.asahi-engineering.co.jp/english>

Contact: **Asahi Engineering Co., Ltd. Kodaira Works**

3-3-22, Gakuen-Higashicho, Kodaira-shi, Tokyo 187-0043, Japan

[E-mail: ae-sales@asahi-engineering.co.jp]

TEL: +81-42-342-4422 FAX: +81-42-342-4423

RTEX Network Motion Control board

MCN-8032P

Features

- RTEX (Real Time Express) servo network
- Network Speed 100 Mbps, communication period 0.5 ms
- Easy to wire, saving wiring working-hour
- Up to 32 nodes
- Excellent error correction
- Multi-axis linear / circular interpolation
- Multi-axis synchronous motion (for gentry)
- Up to 16 boards in one PC



Specification

Item	Description
RTEX motion control	
Module type support	Servo motor drive, Linear motor drive, Stepper drive, I/O module, Pulse module
Max. number of nodes	32 (MCN-8032P)
Max. ring loop length	200 m
Max. node to node length	60 m
Connector / cable type	RJ45 8 pins, STP (Shielding type)
Isolation voltage	1500 Vrms
Noise immunity	Over 2.5 kV
LED loop status	Link / Comm (two elements LED)
Position range	32-bit (± 2147483648)
Motion	
Interpolation	32-axes linear interpolation / 2-axes circular interpolation (max. 16 pairs 2-axes circulator interpolation)
Gantry motion	Max. 31 slave axes can follow the master axis to move synchronously
Position compare signal	All servo axis, up to 1 kHz
Software	
Software utility	MCN80XXP series utility for motion test and diagnosis
Drive/LIB	Drive for Windows 7 (64 / 32 bits), Windows XP, DLL function for windows applications
General specification	
Certification	CE (applying)
Dimension(LxWxH)	175 mm x 100 mm x 20 mm
Power consumption	5 V @ 500 mA
Operation temperature	0 °C to 60 °C

Application Sample

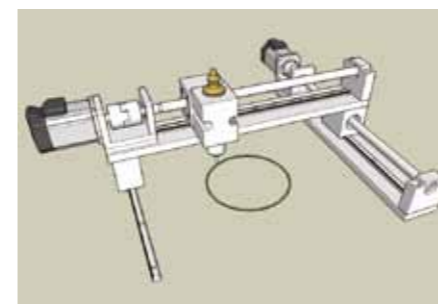

Linear and Circular Interpolations

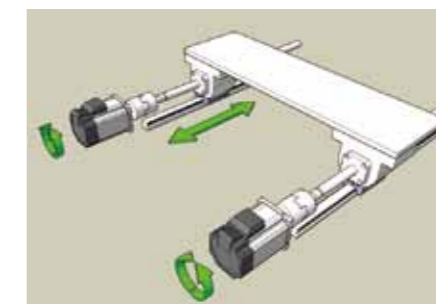

Gentry Motion

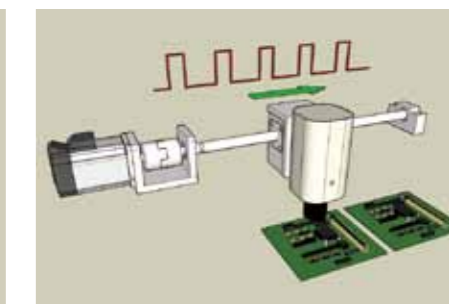

Position Comparing & Triggering Function

System Configuration

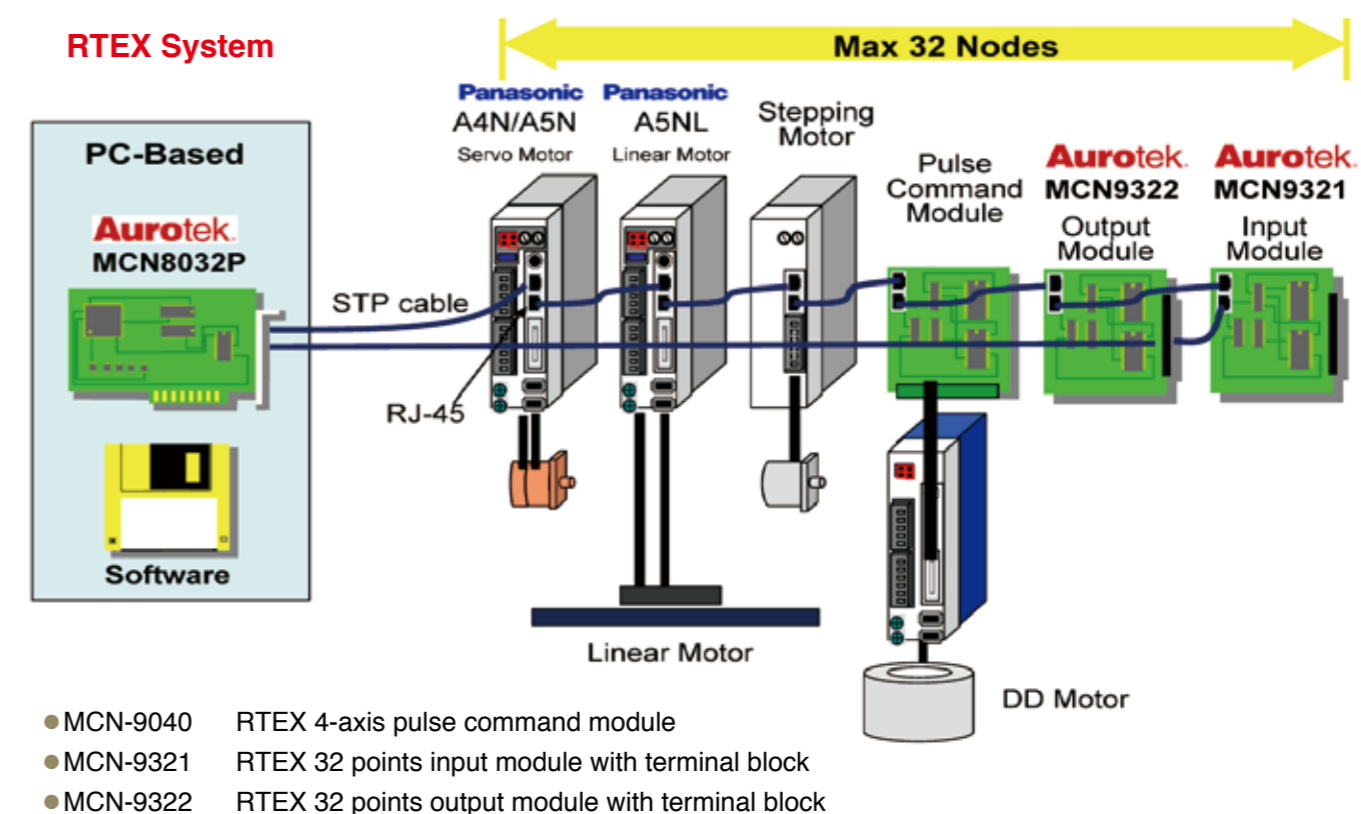

Sales area and Language



- English
- Chinese

For more information

URL : <http://www.robot.com.tw/EN/Default.aspx>

Contact: **Aurotek Corporation**

1st. Floor No. 60, Jhou-Zih St. Nei-Hu District, Taipei 114, Taiwan

[E-mail: sales@robot.com.tw]

TEL: +886-2-6600-7574 FAX: +886-2-8752-3347

Turbo PMAC2 Realtime Express Controller

Turbo-PMAC2-RTEX series

Features

High specification motion controller with built-in PLC

- **Stand alone specification with built-in high-speed DSP (max. 240 MHz)**
Provided with USB 2.0, Ethernet or RS232C as standard port to communicate with host PC. Memory sharing with DPRAM option is possible.
- **Advanced trajectory calculations such as inverse kinematics and look ahead**
Advanced trajectory calculations necessary for linear interpolation, arc interpolation and spline interpolation, and robot control, and CP control by micro line segment feed are provided as standard features. All Turbo PMAC functions such as 2D and 3D positional compensation are available.
- **Various field networks promote multivendor environment (option)**
By adding CC-Link/DeviceNet/Profibus communication module, different manufacturers' devices can be connected.
- **I/O, pulse I/O, A/D and D/A function without intervention of network**
To standard accessories such as universal I/O, pulse input and pulse output, optional A/D and D/A can be added. By using the remote I/O unit ACC-34AA, expansion of 32 inputs, 32 outputs and universal I/O are possible.
Because these can directly access the memory without intervention of a network, they can be easily handled.



Specification

Hardware specification	
Item	Description
Processor	DSP56300 series (Freescale) Standard 80 MHz (option 240 MHz)
Memory	Built-in 128 K × 24-bit SDRAM (option 512 K × 24-bit)
Backup	Settings and program can be stored to Flash RAM.
Communication interface	USB 2.0/Ethernet 100 BASE-TX (concurrent use is not possible), RS232C
Communication Period	Up to 6 kHz (only for Position command)
Power supply	24 Vdc 900 mA Min.
Pulse input	A/B phase rectangular input × 1-ch (6 MHz before multiplied by 4)
Pulse output	Pulse/direction output × 1-ch (max. 1.31 MHz)
Universal I/O	Input 8 points, output 4 points (sink/source selectable) Remote I/O expandable (ACC-34AA)
Universal A/D	12-bit × 2-ch (option)
Universal D/A	±10 V 12-bit × 1-ch (option)

Software specification	
Item	Description
No. of control axes	Max. 32 axes/16 coordinate systems
Controlling method	PTP control, trajectory (CP) control
Interpolation control	2-axis to 9-axis linear interpolation, 2-axis arc interpolation (rotatable) 3-axis spiral interpolation, spline interpolation
Unit of control	Pulse, or other desired industrial metrological unit
Accelerating/ decelerating method	Trapezoid/ S-curve Optional acceleration/ deceleration pattern (PVT mode)
Accelerating/ decelerating time	Min. 1 ms
Positioning range	±2 ³⁵ counts
Position compensation	Ball screw pitch error correction, orthogonal axis correction, plane correction
Other correcting functions	Backlash compensation, tool diameter compensation
PLC function	Interpreter/compile type total: 64 programs
Synchronous control	Electronic gear, electronic cam, motion synchronous I/O output (synchronous M variable)
Advanced trajectory calculation	Look ahead, forward/inverse kinematics operation

Application Sample

From the Simplest Application, to the Most Complex and EVERYTHING in Between...

For details, please check out our Video Center for more information.

URL : http://www.deltatau.com/DT_Resources/VideoCenter.aspx

System Configuration

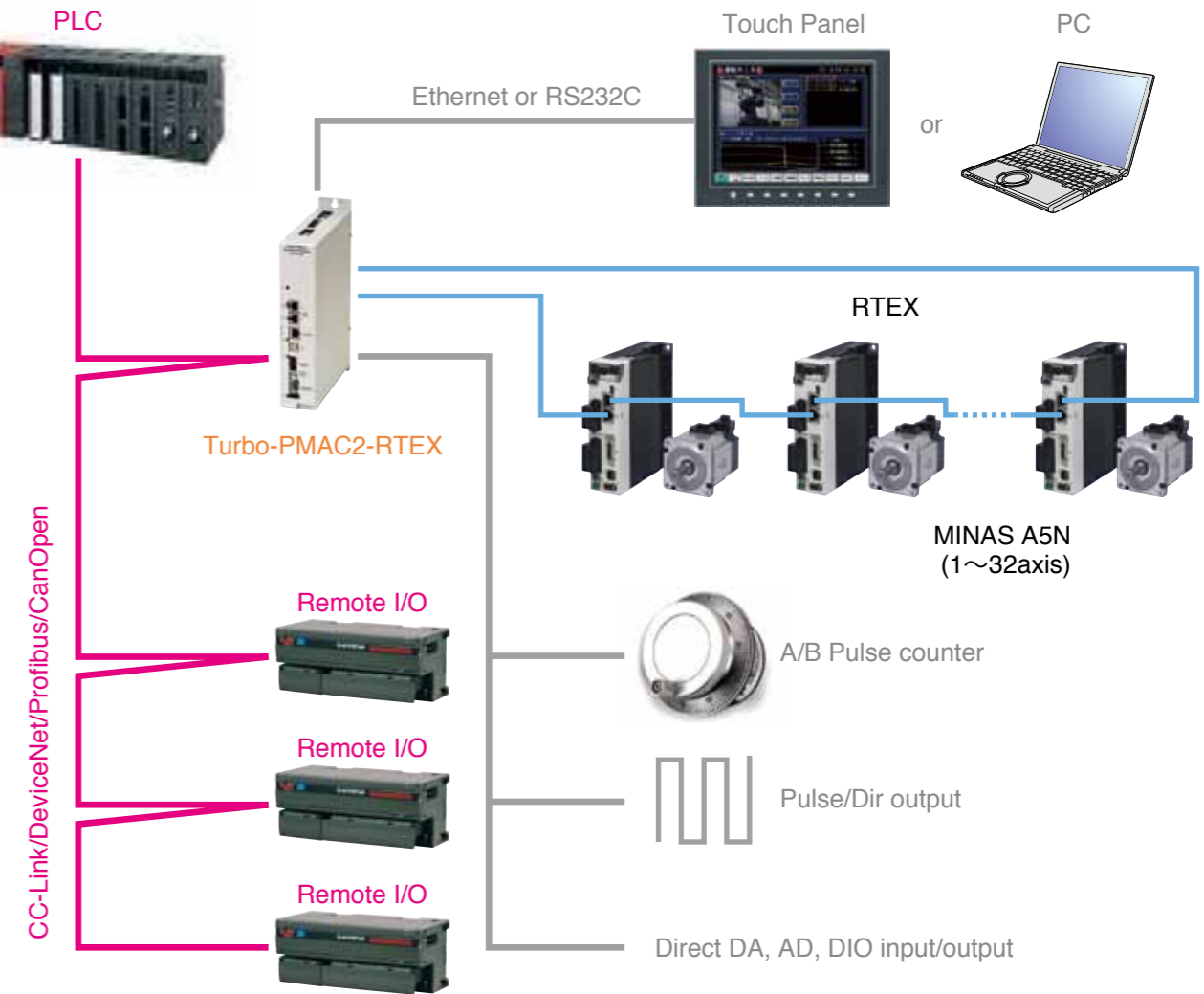

Sales area and Language

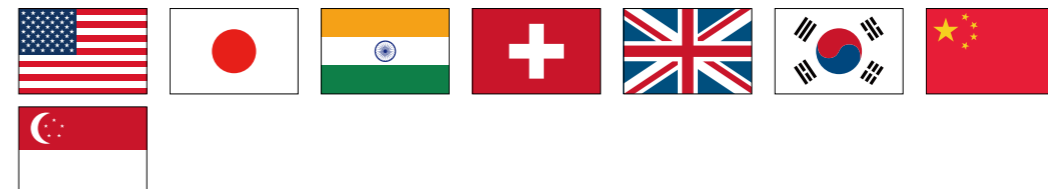

- English
- Chinese
- Korean
- Japanese

Please contact the following URL for details :

URL : http://www.deltatau.com/DT_About/aboutCorporateOffices.aspx

For more information

URL : <http://www.deltatau.com>

Contact: **Delta Tau Data Systems, Inc. USA West Coast Headquarters** [E-mail: sales@deltatau.com]
21314 Lassen Street Chatsworth, CA 91311, United States TEL: +1-818-998-2095 FAX: +1-818-998-7807

PLC Positioning Unit RTEX

AFPG43610, etc.

Features

- Compact PLC is easier to operate to control network servo MINAS A4N/A5N. (Units of Ver.1.3 or later will support A5N.)
- High speed 100 Mbps communications enable high precision arc/linear/spiral interpolation.
- 2-axis, 4-axis and 8-axis units are lined up and can be used to configure system of up to 16 axes with FPΣ and 256 axes with FP2SH.
- User-friendly tool software [Configurator PM] provides strong support for setup, start and monitor.
- Max. No. of position command points is 600/axis and max. position command rate is 32 Mpps, assuring margin of performance.
- Manual pulser input is provided to enable fine teaching.



Specification

Part No. (FPΣ/FP2SH)		AFPG43610/AFP243610	AFPG43620/AFP243620	AFPG43630/AFP243630
No. of control axes		2-axis (2 axes × 1 system)	4-axis (4 axes × 1 system)	8-axis (8 axes × 1 system)
Position control function	Control method	PTP control, trajectory (CP) control		
	Interpolation control	2-axis, 3-axis linear interpolation, 2-axis arc interpolation, 3-axis spiral interpolation		
	Control unit	pulse/ μm/ inch/ degree		
	Positioning data	600 points/axis		
	Backup	Parameter and data table can be stored to FROM.		
	Accelerating/ decelerating method	Linear acceleration/deceleration and S-curve acceleration/deceleration		
	Accelerating/ decelerating time	0 to 10000 ms (in unit of 1 ms)		
	Positioning range	Signed 32-bit (-1073741823 to 1073741823 pulses) increment, absolute designation		
Velocity control function		With JOG operation (infinite feed operation)		
Torque control function		With real time torque limit function		
Origin return	Searching method	Near home (DOG) search, limit search, Z phase search, hit and stop		
	Creep velocity	Setting is optional		
Other		Pulsar input operation/ auxiliary output code, auxiliary output contact/ dwell time/ in position contact/ 2-axis synchronization operation		

* MINAS A4N and A5N cannot be mixed in a system.

Application Sample

- Coil winding machine (Synchronized operation)
- Lens Polish machine
- Inspection machine for electronic device
- Heavy LCD panel handling (synchronized operation)
- Others

System Configuration

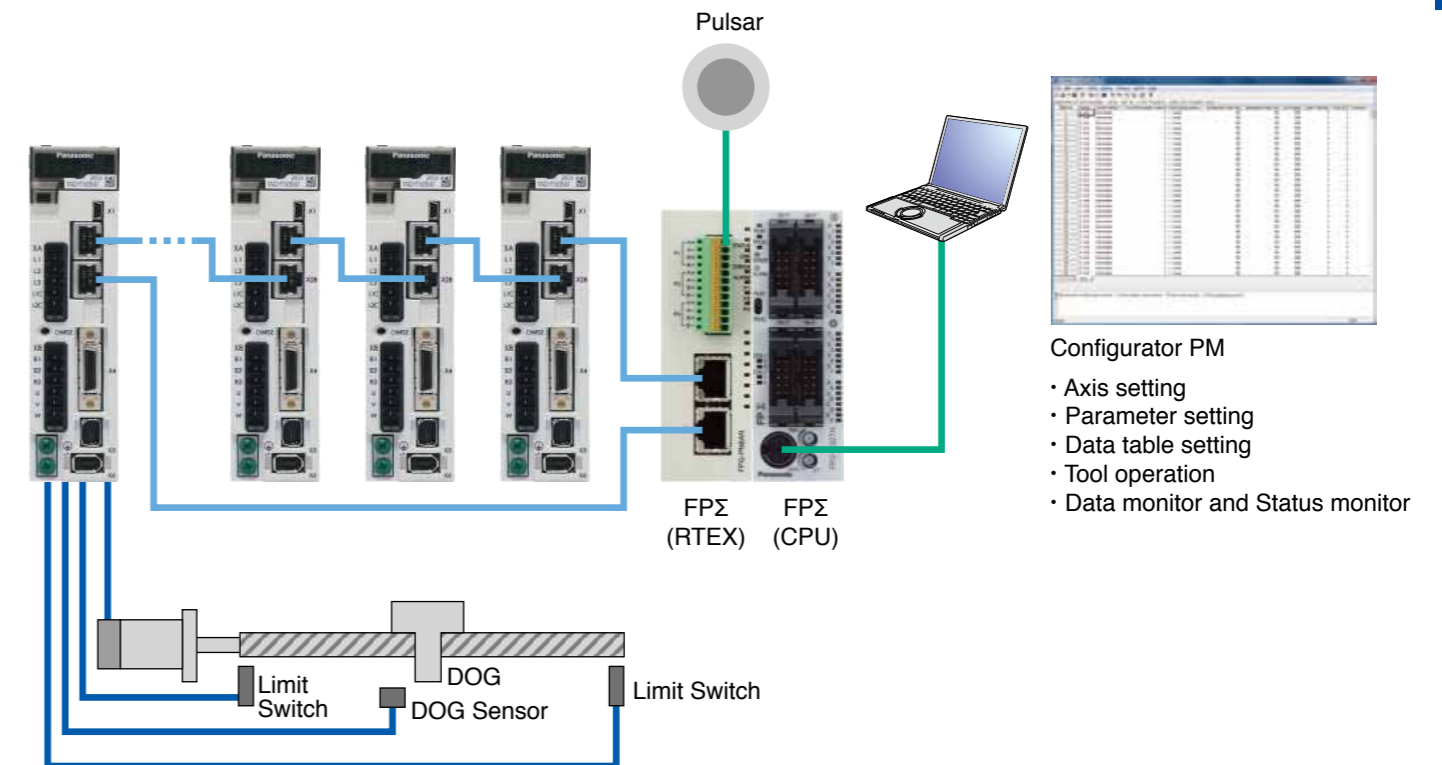

- Configurator PM
- Axis setting
 - Parameter setting
 - Data table setting
 - Tool operation
 - Data monitor and Status monitor

Sales area and Language



- Japanese
- English

For more information

FPΣ URL : <http://www3.panasonic.biz/ac/e/fasys/plc/plc/fpg/index.jsp>
 FP2SH URL : <http://www3.panasonic.biz/ac/e/fasys/plc/plc/fp2sh/index.jsp>
 URL : <http://panasonic.net/id/pidsx/global>

Contact: **Panasonic Industrial Devices SUNX Co.,Ltd.**

2431-1, Ushiyama-cho, Kasugai-shi, Aichi, 486-0901, Japan

TEL: +81-568-33-7861 FAX: +81-568-33-8591

Multi PLC Direct Connection 16-axis Motion Controller [InterMotion] Including PLC (Using C-like Language)

Features

- Directly connectable to Mitsubishi Electric PLC (CPU with Ethernet: e.g. Q03UDECPU) References CPU D register according to MC protocol.
- Directly connectable to OMRON PLC (CPU with Ethernet: e.g. CJ1M-CPU11-ETN)
- Directly connectable to Keyence PLC KV-5000
- Internal control program of [InterMotion] can be developed in the machine control script language [MOS language]. Motion, I/O, communication and sequence can be controlled.
- 1 ms scan DOUT interlocked trajectory control (coating valve control, spray valve control, etc.) is possible.



Specification

Item	Description
No. of control axes	For max. 8 axes, 10 Mpps pulse train position command can be used as necessary. (Low cost version is available: RTEX axis only without pulse train output)
Controlling method	Each axis is independent PTP. Max.8 axes sync PTP. Linear interpolation, 2-axis arc interpolation, 3-axis spiral interpolation, 32-bit length. 1 ms scan DOUT interlocked trajectory control option (coating valve control, spray valve control)
Internal control program development	Control program can be developed by using the C-like multiprocessing machine control language [MOS language]. Motion, IO, communication and sequence can be controlled. As the development environment, [MOS Bench AM] is required.
Accessory IO	±CW, ±CCW pulse output, ±A, ±B, ±Z input. Servo on, reset output. ±OT, alarm input, for 8 axes. Universal IN 8 points. Universal OUT 8 points. Non-insulated RS232 1 ch, Insulated RS485 1 ch. (By adding remote IO, 192 IN and 192 OUT are available.)
Host controller	Mitsubishi Electric PLC with CPU with Ethernet (reference CPU D register) Keyence PLC KV-5000 (reference data memory) OMRON PLC with CPU with Ethernet (reference data memory) Or, Windows PC with Ethernet

Real-time Windows Software 40-axis Motion Controller [RT40PR] Including Software PLC (Using C-like Language)

Features

- 32-axis RTEX Interface
- 8-axis 10 MPPS Pulse Train Output
- Synchronization between RTEX-axis and Pulse Output-axis
- Real-time Windows Software PLC Using the C-like Multi-Process machine control script language [MOS language].
- Same as Motion-card, Input, Output, AD, DA, RS232C, and Counter-card can be controlled under Windows Real-time Environment using [MOS Language]



General Purpose 32/32 Input/Output Board InterMotion Series JOY-RIO3232

Features

- Single board with 32 IN points and 32 OUT points
- 10 PIN connector for 8-point IN and 8-point OUT. Can be directly connected to terminal block PRS-DG10-O8 (TOYOGIKEN Co., Ltd).
- 24 V DC supply



Specification

Item	Description
Input	32 points (8 points × 4 ports), 24 V _{DC} , 4.7 kΩ
Output	32 points (8 points × 4 ports), 24 V _{DC} , 100 mA
Max. No. of connectable boards	6 (IN 192 points, OUT 192 points)

System Configuration

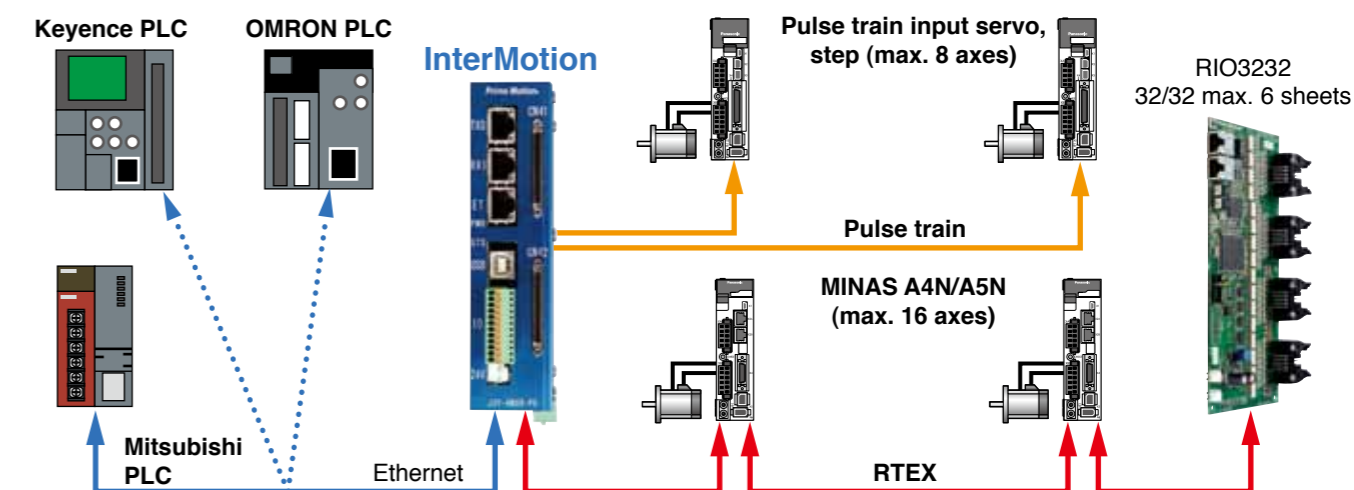

Sales area and Language



• Japanese

Please contact the following address directly in Japanese.
Note) Now preparing for a document in English.

For more information

URL : <http://www.primemotion.com/index.php>

Contact: **Prime Motion Inc.** (InterMotion - Special site: <http://www.intermotion.jp>)
1134-12, Akaho, Komagane-shi, Nagano, 399-4117, Japan TEL: +81-265-82-2990 FAX: +81-050-3774-8184

PCI Bus 32 Block Control Board

PCMC-168N

Provided by COSMOTECHS Co.,Ltd.

Features

- Control data up to 32 block in 0.5 msec communication period
- Continuous Pass control : Up to 16-axis
Point to Point control : Up to 16-block
- Complex movement can be realized by the combination of a linear interpolation and a circular interpolation
- Change and tune servo-parameters at once via RTEX communication
- Easy to start-up in synchronization for all axis



Specification

Item	Description
Number of control axis	32 Block (Motor Control:16-axis, Module : 16-block)
Motor Control	Motor Control LSI × 4 (PMC842S : COSMOTECH)
Max.Pulse Frequency	8.191 Mpps
Command Update Period	0.5 ms
Drive Function	Positioning, Continuous, Mech.signal, Synchronized start, linear, circular and continuous interpolation,
AC/DC Mode	Linear and S-Curve, Asymmetry Linear and S-Curve
Over-ride Function	Change velocity and distance
Counter Function	32-bit Output counter function, Comparator function
Physical Layer	LAN Cable (100BASE-TX)
Size (mm)	174.63 (W) × 106.68 (D)
Other function	Homing, Parameter Setting, Command reservation, Alarm Clear Command, Emergency stop function

Application Sample

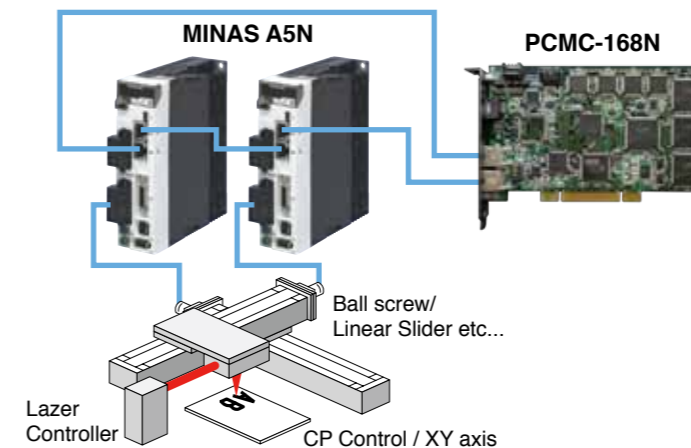

- For continuous pass control like Laser Cutting, Application

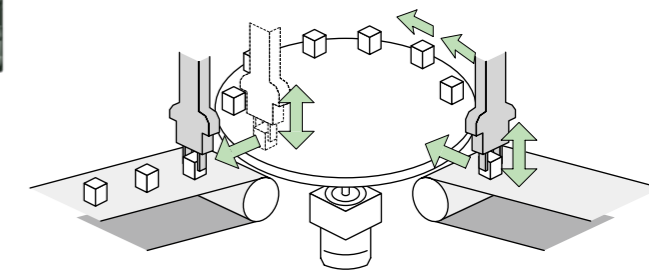

- For Index table, Parts feeder etc.

System Configuration

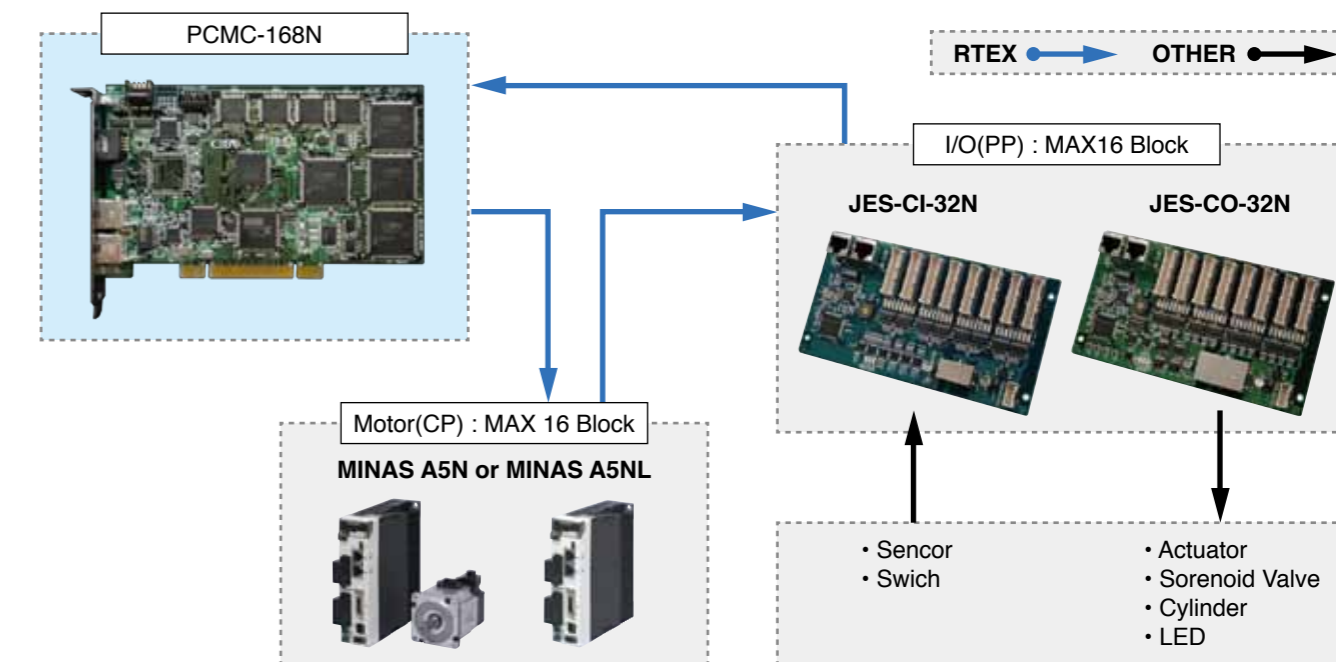

Sales area and Language



- Japanese
- Chinese

Please contact the following address for details.

For more information

URL : <http://www.shhuitong.net/> (Chinese)
URL : <http://www.cosmotechs.co.jp/> (Japanese)

Contact: **Shanghai Bitpass Automation Technology Development Co.,Ltd.**

floor1601 jinyi Mansion.441He Nan N.Rd, Shanghai, China

TEL: +86-21-63570803 FAX: +86-21-63570802

Full-Scale CNC Controller for RTEX

ServoWorks CNC Series

Features

- Complete high-end CNC solution for machining centers, laser, plasma, EDM and grinding machines
- FANUC-compatible, full-scale G code and Ladder programming
- High-speed, high-precision milling functions including velocity override control in circular interpolation, corner deceleration, dual-axis synchronous control, tool center point (TCP) control
- Interpolation rate as fast as 0.5 ms
- ServoWorks Development Kit (SDK) with VB and .NET support
- Various I/O modules available for a hand wheel, digital I/O control and spindle drive control
- Real-time performance on Windows based on industry-proven "Soft Motion" technology

Specification

ServoWorks Series		MC-Quad	S-100M	S-120M	S-140M
Max. No. of control axes		4	8	16	32
Maximum Number of Axes		4	4	8	8
Spindle Control		—	○	○	○
Maximum Number of PLC Axes		—	—	3	2
Max. Number of Interpolated Axes	Linear Interpolation	4	4	5	6
	Circular Interpolation	2 (Helical Interpolation)			
Interpolation Cycles		1 ms (0.5 ms as an option)			
Smoothing Filters		Linear, Bell-shaped, Exponential			
Minimum Machine Unit	Linear Axis	0.000000001 mm, 0.000000001 inch			
	Rotational Axis	0.000000001 deg			
Macro Programming		○			
Automatic Corner Deceleration		○			
Velocity Limit in Circular Interpolation		○			
Lookahead Contour Control		○			
Complete Synchronous Control (Gantry)		○	—	○	○
Tool Center Point Control		—	—	—	○
Normal Direction Control		—	—	—	○
I/O Control (PLC)	Control Cycle	1 ms			
	Max. Step Number	10000			
	Max. Control Points	I: 800 / O: 800			

Application Sample

- Machining Centers
- Milling and Engraving Machines
- Plasma and Laser Cutting Machines
- Dental Milling Machines
- EDM Machines

System Configuration

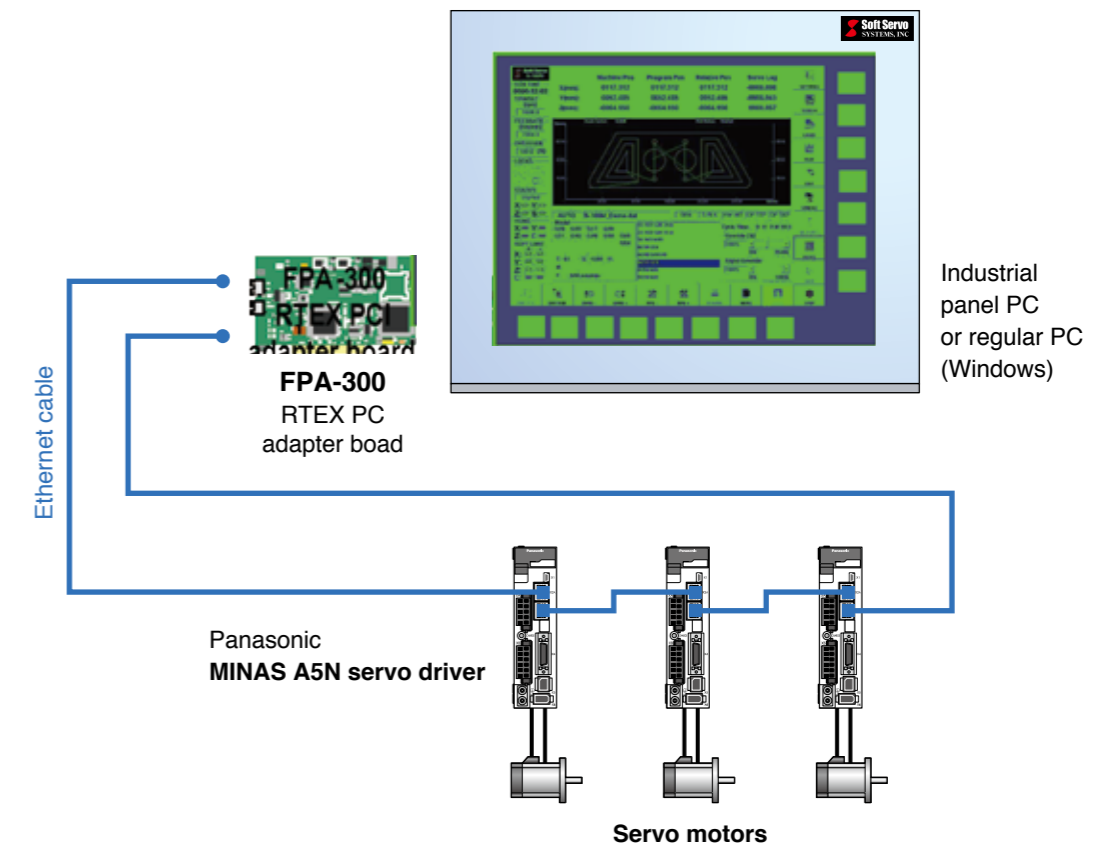

Sales area and Language



- English
- Japanese
- Korean

Please contact the following address for details.

For more information

URL : http://softservo.com/data_sheets/S-100M_Series_DataSheet.pdf

Contact: **SOFT SERVO SYSTEMS, INC.**

272-1 Norieda-cho, Minami-ku, Hamamatsu, 432-8053, Japan

[E-mail: info@softservo.co.jp]

TEL: +81-53-444-5771 FAX: +81-53-444-5773

PCI Motion Control Board

169002-MBP-LE01/01, etc.

Features

Motion control board best suited to build motion control system

- **32 axes synchronous control**
 - Servo control of 32 axes in 1 ms period for various applications.
- **Wide array of external interfaces**
 - Because the board is provided with such external interfaces as RS485 communication, 2 external inputs (24 V compatible) and 1 external output, it can be connected to various devices.
 - When multiple inputs/outputs are required, it supports remote I/O function (CUnet).



Specification

Series list			
Model	No. of control axes	Built-in pulse train conversion software	Built-in PLC
169002-MBP-LE01/01	32	-	-
169002-MBP-LE01/02	32	○	-
169002-MBP-LE01/11	16	-	-
169002-MBP-LE01/12	16	○	-
169002-MBP-LE01/21	8	-	-
169002-MBP-LE01/22	8	○	-
169002-MBP-LE01/23	8	-	○

Item	Description	Remarks	
Architecture	CPU	SH4 HD6417750R 200 MHz	
	Memory	FLASH ROM 8 MB	with backup function
		SDRAM 16 MB	
		SRAM 128 KB	
		EEPROM 8 KB	
	Shared memory 128 KB	For data transfer	
Servo interface	Connector	RJ-45 x 2	
	Interface	Compatible with MINAS A4N/A5N series	
External input	2 PORT (with sink/source switching)		
External output	1 PORT (with sink/source switching)		
Remote I/O	CUnet		
Serial interface specification	Interface	RS-485	MKY40 (Step Technica Co., Ltd.)
	Transmission rate	115.2 kbps (Max.)	
Compatible OS	Microsoft Windows XP	If you use a different OS, consult us.	

Application Sample

- Semiconductor equipment
- Chip-Mounter
- Machine tool
- Industrial Robot

System Configuration

Sample 1 : In case that the customer develops the motion software

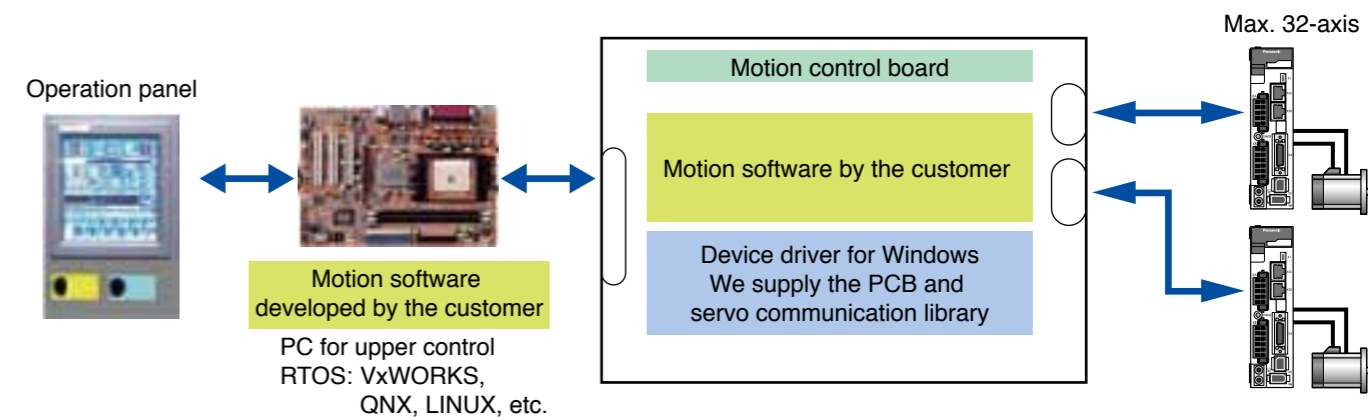

Sample 2 : In case that the customer uses installed software and develops the upper application.

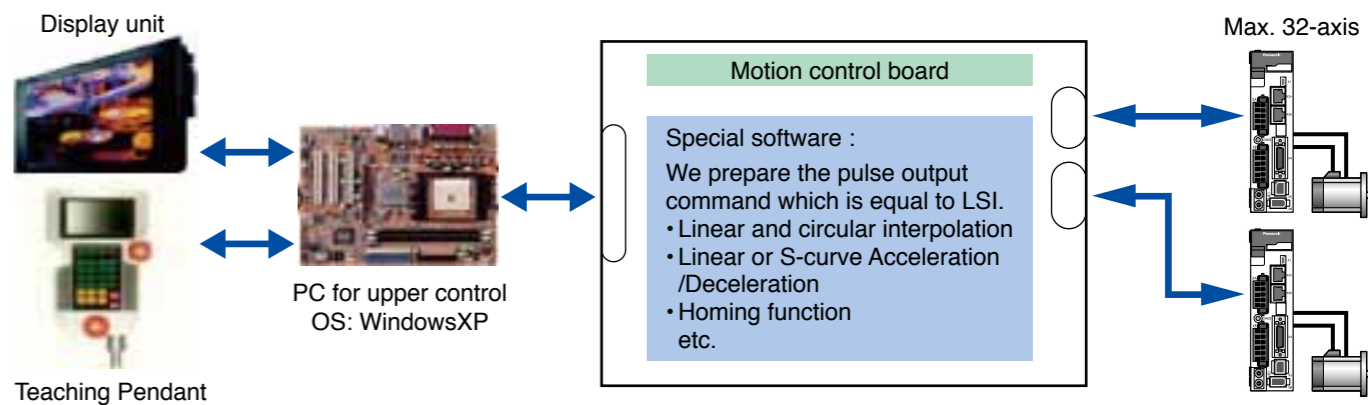

Sales area and Language



- Japanese
- English

For more information

URL : <http://www.tietech.co.jp/english/index.html> (Japan)

URL : <http://www.tietech.com.cn> (China)

Contact: **TIETECH Co.,Ltd.**

1-3-4 Shioya-cho, Minami-ku, Nagoya 457-0078, Japan

TEL: +81-52-824-7375 FAX: +81-52-811-4737

PLC Motion Unit

B3632101-UNT-LE02

Features

PLC motion unit best suited to build motion control system

- **32 axes synchronous control**

All servos sync to the host device assuring precise CP control.

Communication period is 1 ms over max. 32 axes allowing various control settings.

- **Software interface easily transportable from pulse train type software**

Command functions such as single axis PTP control, linear interpolation, arc interpolation, origin return and drive parameter change are provided. The unit will operate as the host controller sets the parameters and calls DLL functions. (DLL functions will be disclosed.)

- **Connection of Yokogawa PLC to Panasonic network servo**

By connecting the unit to the host PLC via PCI bus and to the driving section via network interface, various monitoring operations can be performed without stress.

The combination of the unit and PLC expands functions such as to external signal interface.

A4N/A5N series
Servo drive compatible



Yokogawa Electric
e-RT3 2.0 series
PLC compatible



Specification

Specification	
Max. No. of control axes	32
Positioning data quantity	No limit
Computing period	1.0 ms
PLC connection	PCI
Interface to servo drive	RTEX 100 Mbps
Continuous servo drive	MINAS A4N/A5N series
Emergency stop input	According to host PLC specification *1
External signal interface	According to host PLC specification *1
Manual signal pulsers interface	According to host PLC specification *1
Various monitoring	High-speed data processing via PCI bus
Interpolation	Linear, arc, continuous, multiplex, helical pressure control *1

Item	Description		Remarks
CPU	SH4 7750R 200 MHz (Renesas) Peripheral clock 50 MHz Bus clock 50 MHz		
	Memory	ROM	Flash ROM 8 Mbyte EEPROM 8 kbyte
RAM		SDRAM 8 Mbyte	
		DPRAM 256 kbyte	
Bus		PCI bus interface	Bus width 32-bit
	Clock 33 MHz PCI Rev.2.3 compatible		
Power supply	Internal power supply	Main power supply 5 V/ 3.3 V	
		CPU power supply 3.3 V, 1.5 V	
		FPGA 3.3 V, 2.5 V, 1.2 V	
Watchdog function	WDT	Watching time 1.6 s	
Monitor	LED	2 points	RUN Green LINK Green Blinks during operation
Communication	RS232C	1-ch	
	RTEX	1-ch	
Setup	DIPSW	Universal input 4	
		For JTAG.ICE connection 1	
		For FPGA setting 2	
OS	VxWorks6.4		

*1 May be separately defined.

Application Sample

- Semiconductor equipment
- Chip-Mounter
- Machine tool
- Industrial Robot

System Configuration

Sample 1 : In case that the customer develops the motion software

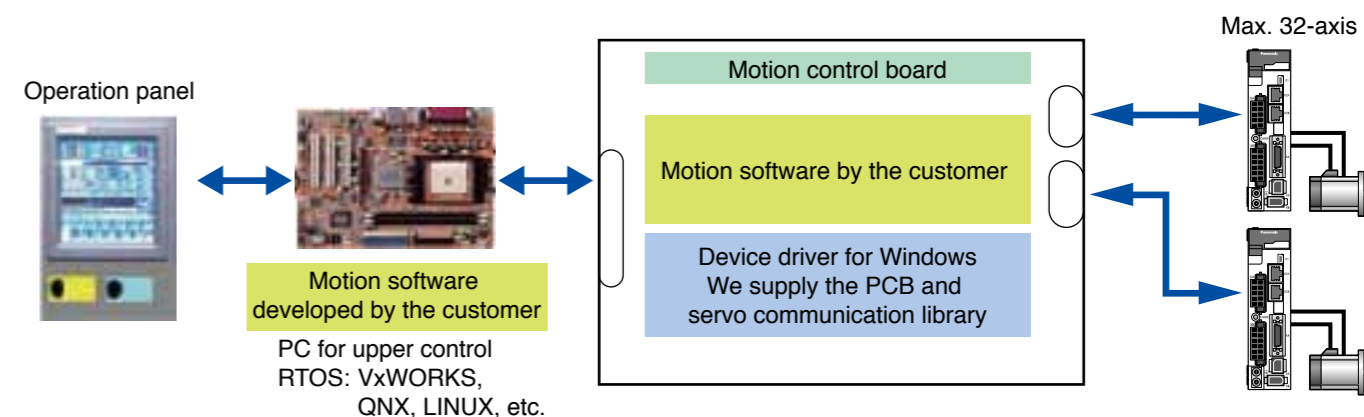

Sample 2 : In case that the customer uses installed software and develops the upper application.

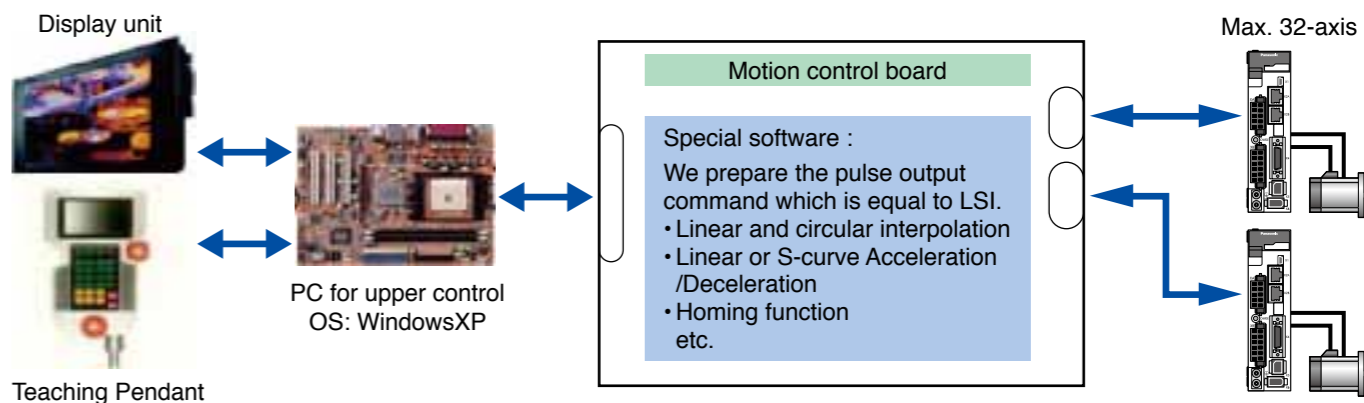

Sales area and Language



- Japanese
- English

For more information

URL : <http://www.tietech.co.jp/english/index.html> (Japan)

URL : <http://www.tietech.com.cn> (China)

Contact: **TIETECH Co.,Ltd.**

1-3-4 Shioya-cho, Minami-ku, Nagoya 457-0078, Japan

TEL: +81-52-824-7375 FAX: +81-52-811-4737

Motion Coordinator and RTEX Interface Module

Motion Coordinator MC464 / Panasonic RTEX Interface Module

Features

- Supports digital drive systems up to 64 axes using multiple RTEX
- Based on 64-bit 400 MHz MIPS processor
- Anybus-CC Module support allowing flexible factory communication options
- High accuracy double floating point / 64-bit integer resolution
- Multi-tasking BASIC programming
- IEC 61131-3 programming support
- Backlit LCD display
- Ethernet programming interface
- Expansion flexibility with clip on modules allowing quick interchangeability
- Built-in Ethernet-IP connectivity



Specification

Item	Description	
MC464		
System Flexibility	Axes Controlled	Up to 64
	RTEX Drive Networks	Up to 7
	Built-in Synchronization Encoder Input	Yes
Programming	Multi-Tasking TrioBASIC	Yes
	Number of Simultaneous Programs	30
	Motion Perfect Windows Software	Yes
	Stand-Alone operation	Yes
	Permanent Flash EPROM for program storage	Yes
	Available memory for user programs	8 Mbyte
	User table memory	512000
	Accurate and fast real number mathematics	64-bit Int / Double Floats
	Program Trace Debugger	Yes
	Named Constants and variables	Yes
Motion Functions	Linear, Circular, Helical, Spherical Interpolation	Yes
	Cams, Gearbox, Clutches	Yes
	64-bit position storage	Yes
	Acceleration/Deceleration & S-Ramp Controls	Yes
	5 Term Control	Yes
	Max Interpolated Axes	64, Multiple groups
Interfaces	Hardware Position Capture (Registration)	1 µs
	Ethernet port	10/100 Base-T
	RS232 Serial Port	128 kbps
	RS485 Multi-Drop	Yes
	Ethernet IP	Yes
	Modbus TCP	Yes
	Anybus Module	Yes
	Opto-Isolated Inputs	16
	Opto-Isolated Outputs with current limit	8
	Max Input / Output Expansion Channels	512
	CAN Analogue Inputs Capability	Yes
	Real Time Clock	Yes
	SD Card	Programs and data
Packaging	Module case style	DIN Rail / Panel Mount
	Module size (H x W x D)	201 mm x 155 mm x 56 mm
	UL and CE marked for EMC	Yes

Item	Description
Panasonic RTEX Interface Module	
Network	Ethernet based MINAS A4N / A5N
Network Speed	100 Mbps 1msec or 500 usec update operation
Topology	Ring
Max Slaves per Interface Ring	32
Max Interfaces per MC464	7
Max Axes per MC464	64
Bus to MC464	32-bit
Registration Inputs	8 x 24 V Inputs + 1 Drive Registration Input/Axis
Optically Isolated registration Inputs	Y
Map Any I/O to Any Axis	Y
Supported Modes	Cyclic Position, Cyclic Speed, Cyclic Torque

Application Sample

URL : Sample applications

http://www.triomotion.com/tmt3/sitefiles/motion_control/applications.asp#section=overview

Please refer to the sample and typical applications for the MC464 with A5N as shown above URL.

System Configuration

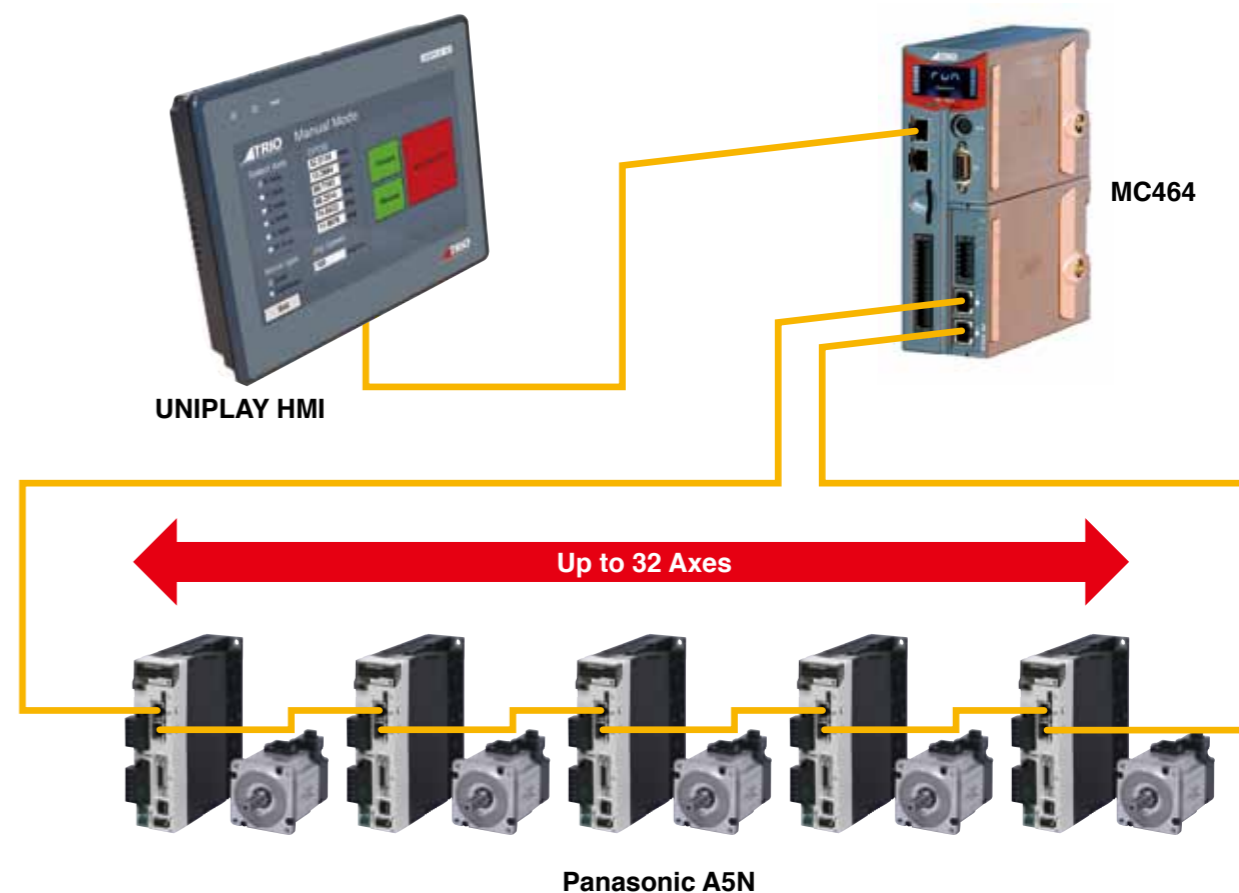

Sales area and Language



• English

Please contact the following address for details.

For more information

URL: Panasonic Expansion Module

http://www.triomotion.com/tmt3/sitefiles/products/exp_mod_panasonic.asp#section=one

URL: The specifications for the MC464

<http://www.triomotion.com/tmt3/sitefiles/products/mc464.asp#section=one>

Contact: **Trio Motion Technology Ltd.**

Shannon Way, Tewkesbury, Gloucestershire, GL20 8ND, United Kingdom TEL: +44-1684-292333 FAX: +44-1684-297929

Motion Master Control Board

HCRTEXsd (-PCI)

Features

- **Motion of up to 32 axes (nodes) can be controlled from the single board.**
The board can control up to 32 nodes of axes and peripheral devices.
- **Simple sequence function reduces the load on host PC.**
- **Parameters and status of servo drive and motor can be uniformly managed from the host.**
Parameter setting and changing of servo drive (MINAS-A5N), various monitoring (alarm, limit signal, etc.), diagnosis of condition and troubleshooting can be easily performed.
- **Flexible expandability by expanding peripheral lineup**
In addition to control of MINAS-A5N, system can be extended to the desired degree by making use of peripheral boards (DI/DO board, Stepper drive board and pulse output board).
- **Full software control**
Speed (linear, S-curve acceleration/deceleration) and trajectory (linear and arc interpolation) are fully controlled by software, precisely at a low cost.



HCRTEXsd



HCRTEXsd-PCI

Specification

Item	Description		
Part number	HCRTEXsd	HCRTEXsd-PCI	
Board specification	Host interface	USB2.0 Highspeed (480 Mbps)	PC15 V/3.3 V signal environment compatible (PCI Spec2.1 Target)
	Power supply	24 V _{DC} ±15% 300 mA MAX	+3.3 V _{DC} , 0.96 A (TYP) +5 V _{DC} , 0.2 A (TYP)
	Operating temperature and humidity	0 °C to 50 °C, 85 %RH max. (no dewing)	
	Outline dimensions (mm)	W130 × D150 × H30	W167.64 × D64.41 (PCB only) 1 slot, LowProfile compatible
Board function	No. of control nodes	32	
	Motion control	Positioning control by software	
	Motion function	<ul style="list-style-type: none"> • Positioning, linear and arc (continuous) • Linear, S-curve acceleration/deceleration (triangle driving avoidance function) • Software accurately maintains arc circumferential velocity constant • Simple sequence function • Setting and reading of servo drive (MINAS-A5N) parameters • Other motion functions 	

Specification

MCRTEX2sd



2-axis pulse output board

- One board can control 2-axis motor (occupies 2 blocks)
- 1 pulse/2 pulse/2-phase pulse output is possible. Pulse train input type drive can be connected, regardless of stepping or servo. (Differential output)
- Up to 8 Mpps pulse can be output, enabling high speed, high resolution control.
- Feedback pulse counting is possible. UP/DOWN, A/B phase (multiplied by 1/2/4) signals can be used for counting.

INRTEX16sd/OTRTEX16sd



DI board and DO board

- INRTEX16sd**
- Input configuration : Photocoupler isolated
 - No. of inputs : 16
 - Rated voltage : +24 V_{DC}
- OTRTEX16sd**
- Output configuration : Photocoupler isolated open collector (sink)
 - No. of outputs : 16
 - Output rated voltage : +24 V_{DC}
 - Output rated current : 100 mA Max.

ADRTEX2sd



2-ch analog input board

- No. of input channels: 2
- Input configuration : Differential/single end
- Input range : ±10 V, ±5 V, 0-0 V
- Resolution : 12-bit
- Conversion mode : Free run/external trigger

System Configuration

- Common communication system (RTEX) optimizes control method and connections, facilitating building of simple system.

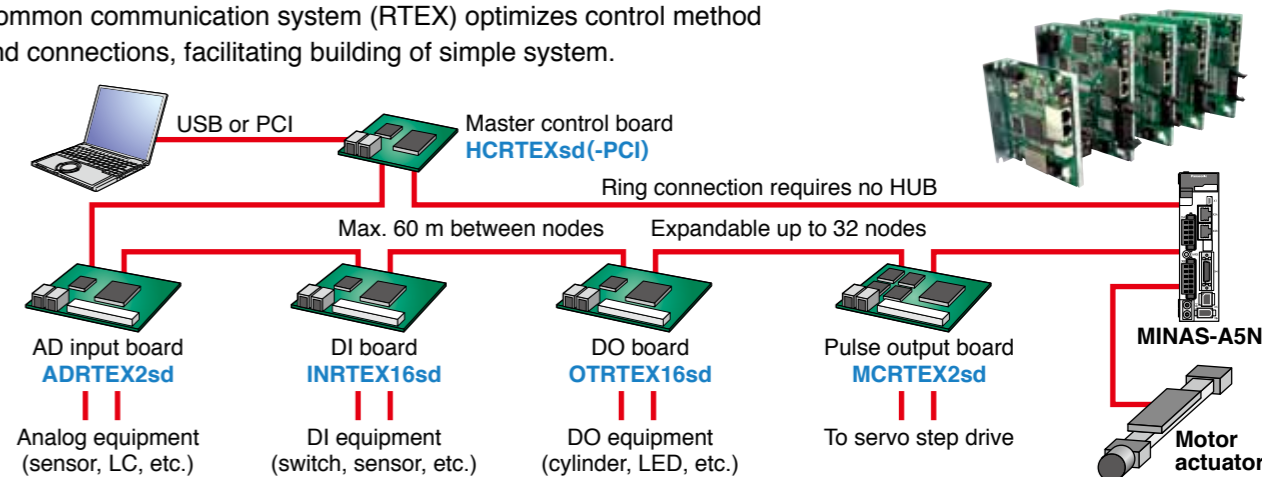

Sales area and Language



- Japanese
- English

Only Japanese is used for inquiry over the phone.
When making an inquiry in English, please send it to the following address.

For more information

URL : <http://www.hp-vanguard.com/>

Contact: **HI-P Tech Corporation Sales Dept.** [E-mail: sales-div1@hp-vanguard.com]
1-27-23, Higashitokorozawa, Tokorozawa-shi, Saitama 359-0021, Japan TEL: +81-4-2951-5381 FAX: +81-4-2951-5383

RTEX/AnyWire Gateway

AG42-R1

Features

Connect AnyWire Reduced Wiring I/O System to RTEX

- AnyWire reduced wiring system has Dual-Bus function which transfers DI/O and AI/O on the same transfer line but independent of each other.
- AnyWire reduced wiring system is cable free specification and uses general purpose wires
- Layout free, e.g. T branch, multi drop and tree wiring
- Simple one-touch connection, branch and extension by using insulation displacement connector
- Max. No. of I/O points is 2560 and max. No. of units connected to I/O terminal is 128
- Max. connecting route length 1000 m



Specification

Item	Description
RTEX	
No. of exclusive blocks	3 to 11 (depending on No. of points used)
Effective data transmission rate	183 kbps/256 points (@ transfer clock: 62.5 kHz)
Transmission scheme	Full quadruplex total frame cyclic system
Synchronization system	Frame/bit synchronization system
Data length/frame	1-bit to 1024-bit
Connection topology	Bus (multi drop, T branch, tree)
Transmission protocol	Dedicated protocol (AnyWireBus)
Error control	Double check
AnyWire	
Max. No. of connecting I/O points¹	Bit-Bus 512 points (IN 256 points + OUT 256 points) Word-Bus 2048 points (IN 1024 points + OUT 1024 points) or 128 words (IN 64 words + OUT 64 words)
Max. No. of connected units	128 (Total of Bit-Bus terminals and Word-Bus terminals)
Max. cycle time²	[0.85 ms/128 points], [1.4 ms/256 points], [2.4 ms/512 points], [4.4 ms/1024 points] (transfer clock @62.5 kHz)
RAS function	Transmission line breakage position detection and transmission line short-circuit detection
Transmission cable³	Cable free • General purpose (VCTF) 2-core /0.75 mm ² to 1.25 mm ² : transmission only (D, G) • General purpose (VCTF) 4-core /0.75 mm ² to 1.25 mm ² : including power supply (D, G, 24 V, 0 V) • Other general purpose cables /0.9 mm ² to 1.25 mm ² : e.g. parallel • Special flat cable /0.75 mm ² to 1.25 mm ² : including power supply (D, G, 24 V, 0 V)
Max. transmission distance⁴	[1 km/7.8 kHz] [500 m/15.6 kHz] [200 m/31.3 kHz] [100 m/62.5 kHz]

*1: The number depends on the master. *2: Typical values at the top speed. *3: Diameter varies with transmission distance.

*4: Distance is the cable total length.

Sales area and Language



- English
- Japanese

Only Japanese is used for inquiry over the phone.

When making an inquiry in English, please send it to the following address.

For more information

URL: <http://www.anywire.jp/>

Contact: **Anywire corporation Headquarters**

[E-mail: info_e@anywire.jp]

1 Babazusho, Nagaokakyo-city, Kyoto 617-8550, Japan

TEL: +81-75-956-4911 (Japanese only) FAX: +81-75-356-1613

* Only Japanese is used for inquiry over the phone. When making an inquiry in English, send it to: info_e@anywire.jp.

RTEX corresponding table and ASIC information

RTEX partner products

[Corresponding table]

Partner	Master				Slave				
	PCI	USB	Stand Alone	PLC	Digital I/O	Analog I/O	Pulse Output	Stepper Driver	Gateway
AJINTEK CO., LTD.	●				●	●	●		
Anywire Corporation									●
Asahi Engineering Co., Ltd.			●					●	
Aurotek Corporation	●				●		●		
Delta Tau Data Systems, inc.			●						
Panasonic Industrial Devices SUNX Co., Ltd				●					
Prime Motion Inc.			●		●				
Shanghai Bitpass Automation Technology Development Co., Ltd with Cosmoteck Co.,Ltd.	●				●		●	●	
SOFT SERVO SYSTEMS, INC.	●								
TIETECH Co., Ltd.	●			●					
Trio Motion Technology Ltd.			●						
Vanguard Systems Inc.	●	●			●	●	●		

Communication ASIC MNM1221

For developing RTEX product, this ASIC is necessary. (See note)



	Specification
Part No. for ordering	DV0P444-9
Packing quantities	90
Power supply voltage	3.3 V
Current consumption	Max. approx. 100 mA (for reference)
Operating ambient temperature	-40 °C to +85 °C
Package	LQFP100pin 14 mm × 14 mm Lead pitch 0.5 mm
RoHS	Compliant
Operation mode	Master/slave

Note: As long as the target is noncompetitive to Panasonic products. For disclosure of technical data, nondisclosure agreement (NDA) is required. For details, consult us.

RS485 Communication MINAS A5A series

AE-LINK RS485 open network

PTP control by servo built-in positioning function

- ▶ Positioning unit is not required
- ▶ Universal RS485 communication without using specific IC
- ▶ Low cost with Ethernet cable
- ▶ Adopted New Algorithm “Two-degree-of-freedom control” (2DOF) to improve productivity and machining accuracy.



[Typical system configuration]

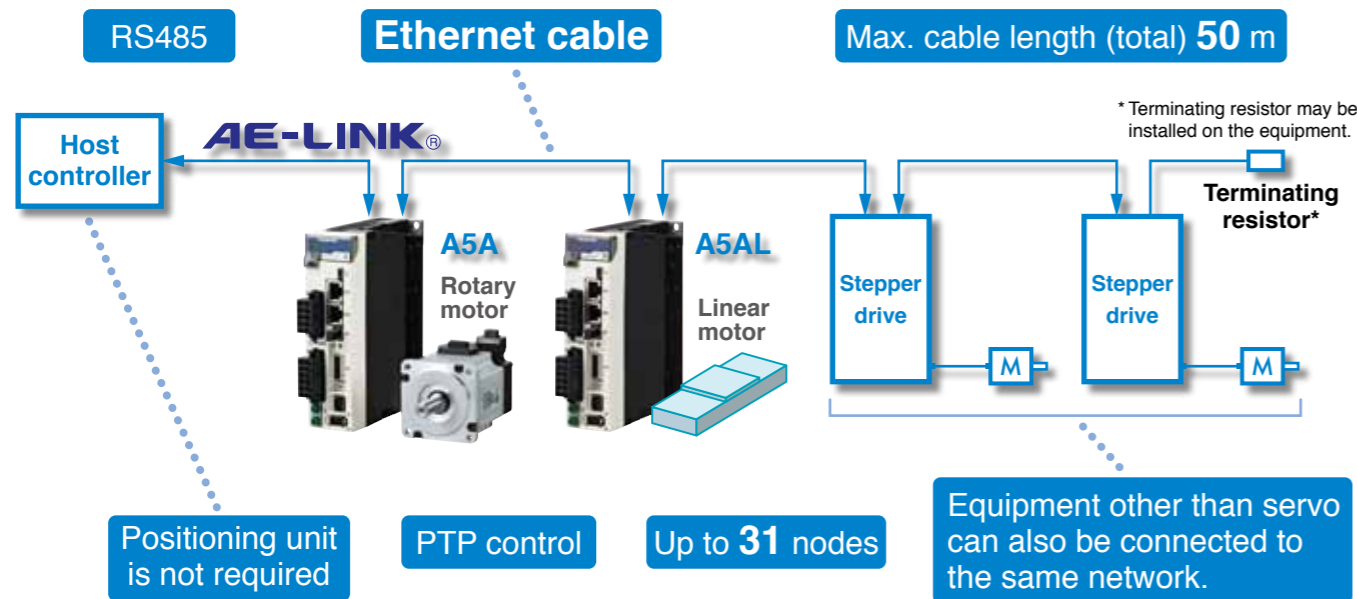

● Application specific IC is not required.

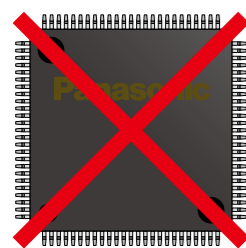

● Cable cost 1/10

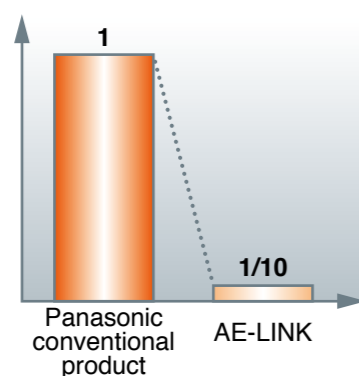

● Network specification

Item	Description
Communication rate	38.4/307.2 kbps
Physical layer	RS485 half duplex
Cable	Shielded twisted pair cable
Communication period	Approx. 1 ms/axis (@307.2 kbps)
Topology	Bus (terminating resistor is required)
Operating command	Target position

Drive list

		Motor rated output										
		50 W	100 W	200 W	400 W	750 W	1 kW	1.5 kW	2 kW	3 kW	4 kW	5 kW
Drive power supply	Single phase 100 to 120 VAC	A	A	B	C							
		MADH T1105A	MADH T1107A	MBDH T2110A	MCDH T3120A							
	Single/3-phase 200 to 240 VAC	A	A	B	C	D						
MADH T1505A		MADH T1507A	MBDH T2510A	MCDH T3520A	MDDH T5540A							
3-phase 200 to 230 VAC								E	F	F		
								MEDH T7364A	MFDH TA390A	MFDH TB3A2A		

Upper line: Frame size symbol

Lower line: Typical drive model No.

Note: Some motors do not match model numbers in the table. Check correct combination in the A5 family catalog.

Appearance

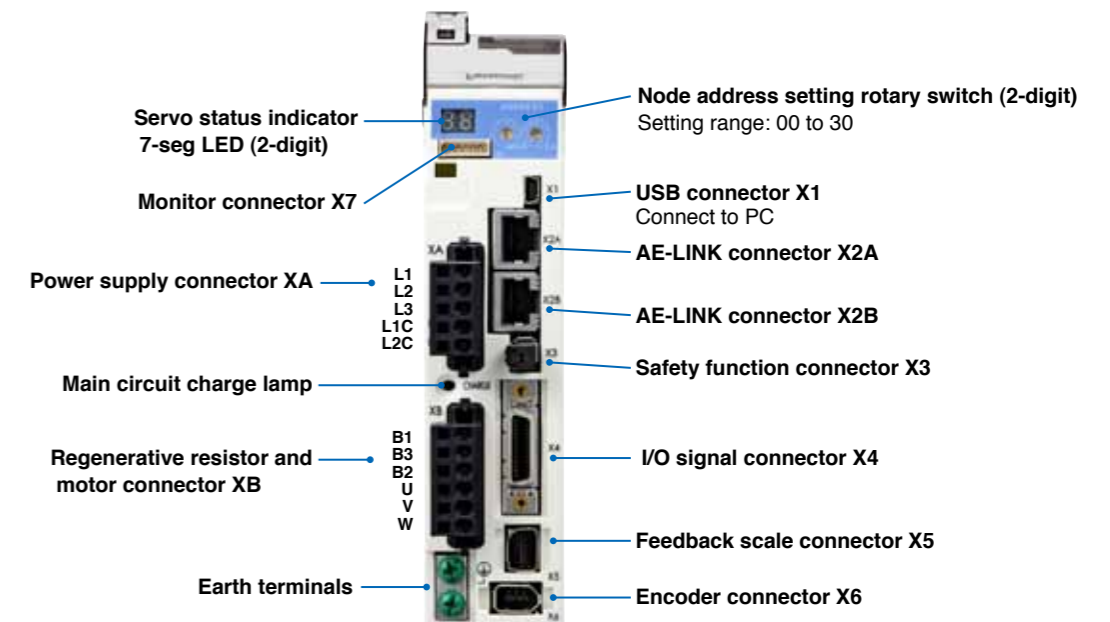

Dimensions (mm): W40 × H150 × D135 (A frame)

Applicable standards



PLC Direct Access AE-LINK Motion Controller

PI-1200 (RS-232C) / PI-1300 (Ethernet)

Features

Building a motion network at low cost under PLC

● PLC direct access

The controller runs the motion program installed in PI while accessing PLC data register.

- Preparation of ladder program for communication is not required on PLC.
- No CPU burden on PLC.

● Simple motion control through data register

Motors can be controlled by operating PLC data register.

- Multiaxial motors can be controlled/monitored by simply operating numeric values on the data register.
- PLC operator having no knowledge on communication of motion (AE-LINK) can control the motor.

● Stepping motor can be mixed

- The motion network can contain servo motor and stepping motor.



PI-1200

PI-1300

Specification

Item	Description
Power supply	24 V _{DC} ±10 % 300 mA MAX
Operating temperature and humidity	0 °C to 50 °C, 90 %RH max. (no dewing)
Outline dimensions (mm)	W24 × D110 × H150 (PI-1200), W25 × D109 × H184 (PI-1300)
Communication with PLC	PI-1200: RS-232C 115.2 kbps/38.4 kbps Conforms to various corporate protocols. PI-1300: Ethernet 10/100 BASE-T Conforms to various corporate protocols.
Program loader	RS-232C 38.4 kbps
Control signal I/O	Initialization input, system alarm output and node alarm output
Motion network	AE-LINK 307.2 kbps/38.4 kbps (Selection on DIP switch)
No. of connection nodes	Max. 16
Motion control	PTP (Point to Point)

AE-LINK Compatible Stepping Motor Drive Series

Features

Building servo and step mixed motion network at a low cost

● Drive has built-in software NC, requiring no host NC controller

● High performance CPU enhances drive functionalities

- Built-in origin return function
- Triangle driving prevention function
- Step-out detection function
- Motor over current protection function
- Vibration suppression function

● Up to 31 axes can be connected to the same network (Depending on the master specification)



Specification

Part No.	Input power supply	Applicable motor	Driving capacity	Step-out detection	Drive outline
D4730S	24 V _{DC}	2-phase	1.5 A/phase		Board type micro step drive
D3080S1	24 to 48 V _{DC}	2-phase	2.55 A/phase	○	High precision micro step drive
D3080S2	24 to 48 V _{DC}	2-phase	5.1 A/phase	○	High precision high power micro step drive
D4390S	100 VAC	2-phase	2.55 A/phase	○	AC supply input high precision micro step drive
D4370S	24 V _{DC}	5-phase	1.5 A/phase		Board type half step drive
D4130S	24 V _{DC}	5-phase	1.5 A/phase		High precision micro step drive

Application Sample

This controller is suitable for semiconductor manufacturing equipment, machine tools, measuring machines, and other machinery.

“AE-LINK” is a serial communications protocol published by ASAHIENGINEERING CO.,LTD in 1996 for use with motor drivers, sensor, actuator.

In actual many equipment manufacturers have adopted a variety of more than 15 years.

System Configuration

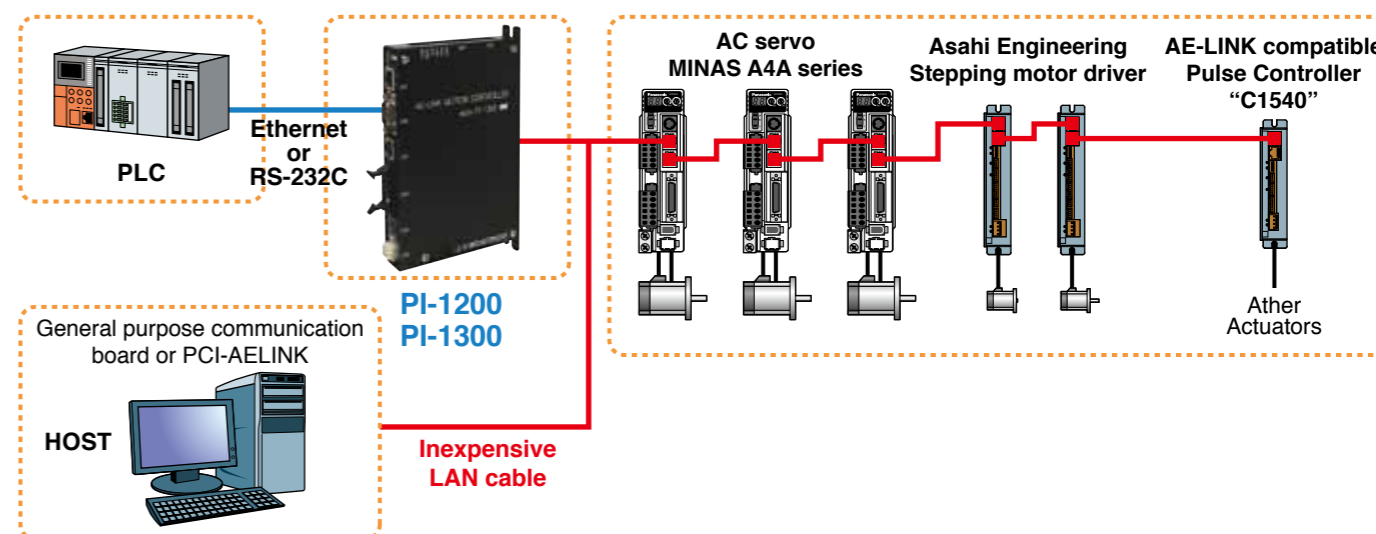

- (1) Accessing PLC data register from PI controller over Ethernet or RS-232C
- (2) Based on the contents of data register. The PI sends command to each axis (motor operation).
- (3) The PI writes status information of each axis to data register.

Sales area and Language



- Japanese
- English

Only Japanese is used for inquiry over the phone.

When making an inquiry in English, please send it to the following address.

For more information

URL : <http://www.asahi-engineering.co.jp/english/>

Contact: **Asahi Engineering Co., Ltd. Kodaira Works**

3-3-22, Gakuen-Higashicho, Kodaira-shi, Tokyo 187-0043, Japan

[E-mail: ae-sales@asahi-engineering.co.jp]

TEL: +81-42-342-4422 FAX: +81-42-342-4423

Linear and direct drive (DD) motor control

MINAS A5L, RTEX type: MINAS A5NL AE-LINK type: MINAS A5AL

A5L

High precision and high speed advancement of linear and DD control drive

Motor

- Various motors such as 3-phase cored/coreless, shaft motor and DD motor

Scale

- Serial communication incremental/absolute and A/B/Z phase pulse scale

Magnetic pole detection

- Both with and without hole sensor signal (automatic detection)

Setup

- Automatic setup of magnetic pole, scale direction, gain, etc.



[Typical system configuration]

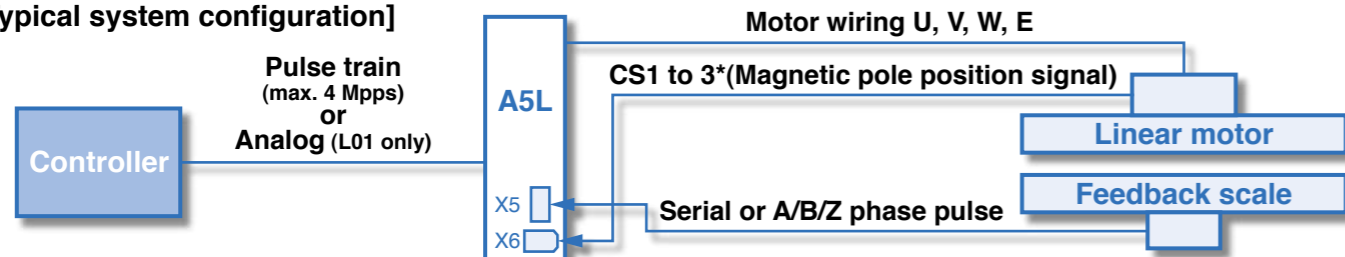

[Setup] • Please ask us to get this software.

Automatic Setup

Automatically sets various parameters such as magnetic pole, scale orientation and gain accordingly to the motor specification.

Drastically reduced setup time.

Automatic Magnetic Pole Detection

When CS signal is not available, the automatic magnetic pole detection function will detect the magnetic pole position of the linear motor.

Short adjustment time without magnetic pole sensor

Simple setup for easy and speedy adjustment

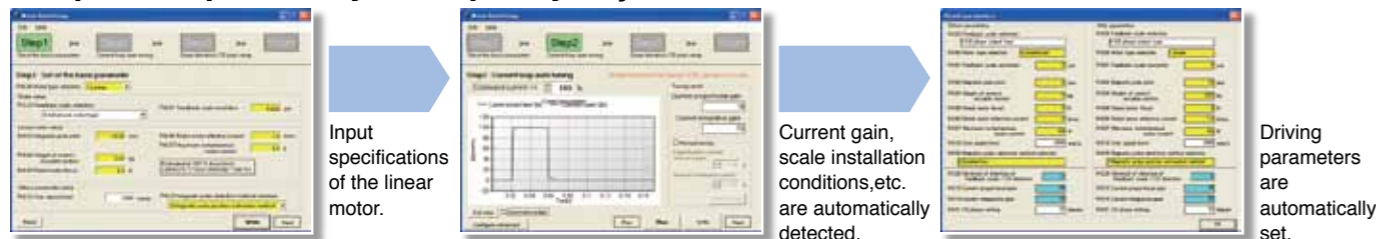

[Lineup] Products of the following two specifications are available with the distinguishable symbol, "L01" or "LA1" placed at the end of the part number.

	L01 [Standard]	Specifications	LA1 [Pulse only]
	Position, speed and thrust command	Instruction	Position command
	Capable	RS232 & RS485 interfaces	N/A
	Compliant (Plug for Safe Torque Off)	Safety function	N/A
	Capable (Can use speed and torque limits)	Analog input	N/A (Pulse input only)

A5NL

RTEX / Linear and DD Control Drive



[Typical system configuration] For linear motor

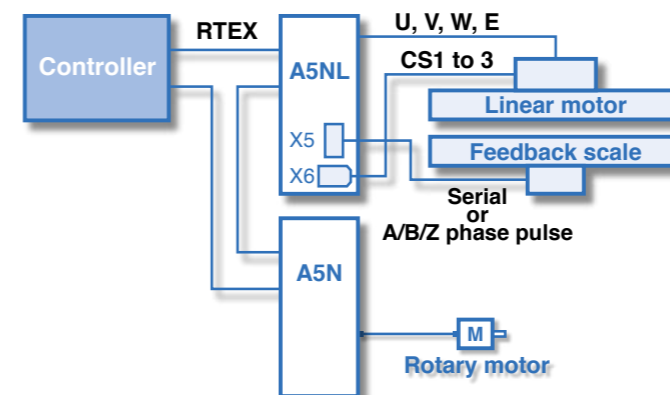

A5AL

AE-LINK / Linear and DD Control Drive



[Typical system configuration] For linear motor

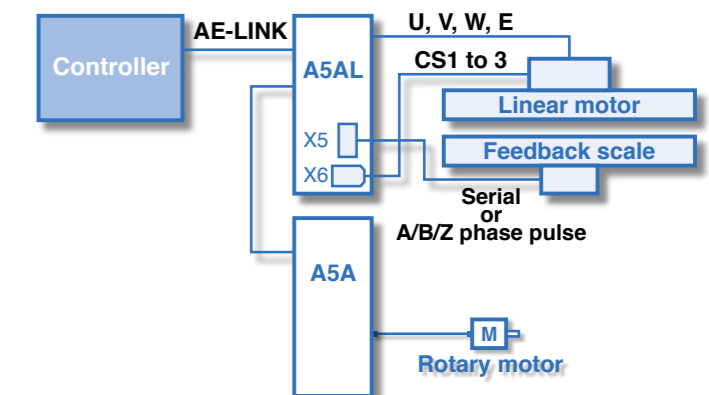

Drive List (Common to A5L and A5NL)

Power supply	Drive Part No. (Note)	Motor rated current [Arms]	Motor max. current [Arms]
Single phase 100 V	MADHT1105***	1.2	3.6
	MADHT1107***	1.7	5.1
	MBDHT2110***	2.5	7.5
Single/3-phase 200 V	MCDHT3120***	4.6	13.8
	MADHT1505***	1.2	3.6
	MADHT1507***	1.6	4.8
	MBDHT2510***	2.6	7.8
	MCDHT3520***	4.1	12.3
	MDDHT3530***	5.9	16.9
	MDDHT5540***	9.4	28.2
3-phase 200 V	MEDHT7364***	13.4	40.2
	MFDHTA390***	18.7	56.1
	MFDHTB3A2***	33.0	84.8
	MGDHTC3B4***	44.0	116.6
	MHDHTC3B4***	66.1	167.2
3-phase 400 V	MDDHT2407***	1.5	4.5
	MDDHT2412***	2.9	8.7
	MDDHT3420***	4.7	14.1
	MEDHT4430***	6.7	19.7
	MFDHT5440***	9.4	28.2
	MFDHTA464***	16.5	42.4
	MGDHTB4A2***	22.0	58.7
	MHDHTB4A2***	33.1	83.7

Note:

Trailing *** in the part number is replaced with the following symbol:

A5L: L01: Standard

LA1: Pulse control only

L04: Standard (2DOF)^{†1}

LA4: Pulse control only (2DOF)^{†1}

A5NL: NL1: Standard

N91: With safety function

A5AL: Please consult us.

†1) 2DOF: Two-degree-of-freedom control

Ironless Brushless Linear Motor

AUM Series

Features

- Ironless technology
- Zero cogging force
- Patented technology
- Ironless linear motors with the highest motor constant and shortest coils lengths
- Large continuous force and peak force



Specification

Performance Parameters	Unit	AUM3				AUM4				AUM5				
		S-S1	P-S2	P-S4	P-S6	S-S1	P-S2	P-S4	P-S6	S-S1	P-S2	P-S4	P-S6	P-S8
Continuous Force, coil @100 °C	N	36.0	72.0	144.0	216.0	56.0	112.0	224.0	336.0	98.0	196.0	392.0	588.0	784.0
	lb	8.1	16.1	32.3	48.4	12.6	25.1	50.2	75.4	22.0	44.0	87.9	131.9	175.8
Peak Force	N	144.0	288.0	576.0	864.0	312.0	624.0	1248.0	1872.0	392.0	1414.8	2829.6	4244.4	5659.2
	lb	32.3	64.6	129.2	193.8	70.0	139.9	279.9	419.8	87.9	317.3	634.6	951.9	1269.1
Motor Constant	N/SqRt(W)	7.24	10.24	14.48	17.74	11.19	15.83	22.38	27.41	19.18	27.12	38.35	46.97	54.24
	lb/SqRt(W)	1.62	2.30	3.25	3.98	2.51	3.55	5.02	6.15	4.30	6.08	8.60	10.53	12.16
Continuous Power	W	24.7	49.4	98.8	148.3	25.0	50.1	100.2	150.3	26.1	52.2	104.5	156.7	208.9
Peak Power	W	395.4	790.8	1581.6	2372.3	777.4	1554.8	3109.6	4664.4	417.9	2721.6	5443.2	8164.8	10886.4
Electrical Cycle	mm	60	60	60	60	60	60	60	60	84.0	84.0	84.0	84.0	84.0
	in	2.362	2.362	2.362	2.362	2.362	2.362	2.362	2.362	3.31	3.31	3.31	3.31	3.31
Max Bus Voltage	V	330	330	330	330	330	330	330	330	330	330	330	330	330
Max Coil Temperature	°C	125	125	125	125	125	125	125	125	125	125	125	125	125
Thermal Dissipation Constant	W/°C	0.33	0.66	1.32	1.98	0.33	0.67	1.34	2.00	0.35	0.70	1.39	2.09	2.79
Continuous current	A rms	2.3	4.6	4.6	9.2	2.3	4.6	4.6	4.6	2.5	5.0	5.0	5.0	5.0
Peak current	A rms	9.2	18.4	18.4	36.8	13.0	26.0	26.0	26.0	18.0	36.0	36.0	36.0	36.0
Force Constant	N/A	15.7	15.7	31.4	47.1	24.0	24.0	48.0	72.0	39.3	39.3	78.6	117.9	157.2
	lb/A	3.5	3.5	7.0	10.6	5.4	5.4	10.8	16.1	8.8	8.8	17.6	26.4	35.3
Back EMF Constant	V/m/s	18.1	18.1	36.3	54.4	27.7	27.7	55.4	83.1	45.4	45.4	90.8	136.1	181.5
	V/in/s	0.46	0.46	0.92	1.38	0.70	0.70	1.41	2.11	1.15	1.15	2.31	3.46	4.61
Inductance	mH	3.13	1.57	3.13	4.70	3.50	1.75	3.50	5.25	6.50	3.25	6.50	9.75	13.00
Terminal Resistance @25°C	Ω	4.70	2.35	4.70	7.05	4.60	2.30	4.60	6.90	4.20	2.10	4.20	6.30	8.40
Electrical Time Constant	ms	0.67	0.67	0.67	0.67	0.76	0.76	0.76	0.76	1.55	1.55	1.55	1.55	1.55
Mechanical Parameters														
Coil Mass	g	0.22	0.45	0.91	1.37	0.28	0.56	1.19	1.78	0.73	1.45	2.88	4.32	5.76
	oz	0.484	0.990	2.002	3.010	0.607	1.24	2.62	3.92	1.60	3.19	6.34	9.50	12.67
Coil Length	mm	61	121	241	361	61	121	241	361	85.0	169.0	337.0	505.0	673.0
	in	2.40	4.76	9.49	14.21	2.40	4.76	9.49	14.21	3.3	6.65	13.27	19.88	26.50
Track Mass (per 63 mm)	g	1.00				1.77				4.26				
	oz	2.20				3.89				9.37				
Magnetic Attraction	N (lb)	0				0				0				
Cont. Current	A rms	2.3	4.6			2.3	4.6			2.5	5			
Peak Current	A rms	9.2	18.4			13	26			18	36			
A5L Model		MCDHT 3520L	MDDHT5540L			MCDHT 3520L	MDDHT5540L			MDDHT 5540L	MFDHTA464L			

Application Sample



Single-Axis Module



XY Module

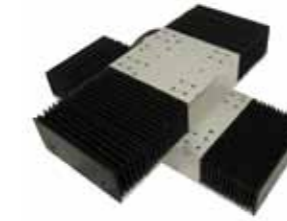

Bellow-Covered Module



Granite Stages

System Configuration

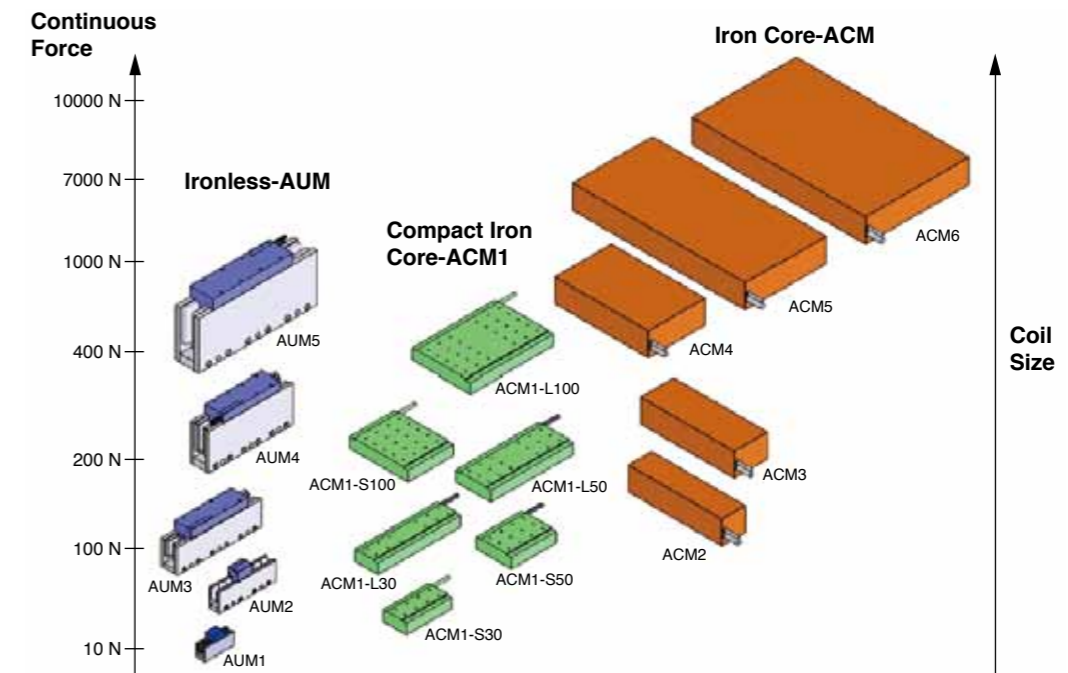

Recommended Drivers:

MADHT1505*, MADHT1507***, MBDHT2510***, MCDHT3520***, MDDHT3530***, MDDHT5540***, MEDHT7364***, MFDHTA390***, MFDHTB3A2*****

Sales area and Language



- English
- Chinese
- Korean
- Thai

Please contact the following address for details.

For more information

URL: <http://www.akribis-sys.com/>

Contact: **Akribis Systems Pte Ltd**

5012 Techplace II Ang Mo Kio Ave 5 #01-05 Singapore 569876

[E-mail: cust-service@akribis-sys.com]

TEL: +65-6484-3357 FAX: +65-6484-3361

Direct Drive Rotary Motor

ADR-A Series

Features

- Direct drive, brushless motor fully integrated with encoder and bearing
- Low cogging torque
- Low speed and high speed windings
- High Continuous and Peak Torque



Specification

Performance Parameters	Units	ADR110		ADR135		ADR175		ADR220		ADR360	
		P-A75	P-A98	P-A90	P-A115	P-A102	P-A138	P-A120	P-A165	P-A150	P-A215
Table diameter	mm	110	110	135	135	175	175	220	220	360	360
Table height	mm	75	98	90	115	102	138	120	165	150	215
Number of poles		16	16	16	16	16	16	24	24	36	36
Continuous torque	Nm	1.9	4.2	5.2	11.0	15.7	32.9	46.0	94.9	184.8	377.9
Peak torque	Nm	5.8	12.6	15.5	32.9	47.2	98.6	137.9	284.6	554.5	1133.8
Torque constant	Nm/A	0.32	0.70	0.86	1.83	1.97	4.11	2.84	5.86	9.24	18.90
Back EMF constant	V/rpm	0.039	0.084	0.104	0.221	0.238	0.497	0.343	0.708	1.118	2.285
Continuous current	A rms	6.0	6.0	6.0	6.0	8.0	8.0	16.20	16.20	20.00	20.00
Peak current	A rms	18.0	18.0	18.0	18.0	24.0	24.0	48.60	48.60	60.00	60.00
Resistance	ohms	0.80	1.21	1.65	2.70	1.30	2.13	0.74	1.20	0.76	1.25
Inductance	mH	4.29	6.49	11.20	18.63	11.27	18.51	6.30	11.90	7.92	13.00
Electrical time constant	ms	5.36	5.36	6.79	6.90	8.67	8.67	8.51	9.92	10.40	10.40
Motor constant	Nm/SqRt(W)	0.36	0.63	0.67	1.11	1.72	2.81	3.30	5.35	10.59	16.90
Mass	kg	3.20	4.60	3.90	5.70	10.0	11.6	15.6	23.4	56.0	71.0
Rotor Inertia	kgm ²	0.0003086	0.0004419	0.000992	0.001332	0.005422	0.007621	0.017858	0.025216	0.204636	0.322304
Rec. max speed @230V AC	rpm	7278	3299	2599	1137	1131	501	770	341	228	98
Rec. max speed @415V AC	rpm	-	-	-	-	-	-	-	-	484	224
MS-12000 optical SINCOS encoder	lines	12000	12000	12000	12000	-	-	-	-	-	-
MS-12000 optical digital encoder (40X)	Counts/rev	480000	480000	480000	480000	-	-	-	-	-	-
Accuracy (based on MS-12000, 40X)	arc sec	+/-27	+/-27	+/-27	+/-27	-	-	-	-	-	-
Repeatability (based on MS-12000, 40X)	arc sec	+/-2.7	+/-2.7	+/-2.7	+/-2.7	-	-	-	-	-	-
MS-16384 optical SINCOS encoder	lines	-	-	-	-	16384	16384	16384	16384	-	-
MS-16384 optical digital encoder (40X)	Counts/rev	-	-	-	-	655360	655360	655360	655360	-	-
Accuracy (based on MS-16384, 40X)	arc sec	-	-	-	-	+/-20	+/-20	+/-20	+/-20	-	-
Repeatability (based on MS-16384, 40X)	arc sec	-	-	-	-	+/-2.0	+/-2.0	+/-2.0	+/-2.0	-	-
MS-23049 optical SINCOS encoder	lines	-	-	-	-	-	-	-	-	23049	23049
MS-23049 optical digital encoder (40X)	Counts/rev	-	-	-	-	-	-	-	-	921960	921960
Accuracy (based on MS-23049, 40X)	arc sec	-	-	-	-	-	-	-	-	+/-15	+/-15
Repeatability (based on MS-23049, 40X)	arc sec	-	-	-	-	-	-	-	-	+/-1.5	+/-1.5
Radial runout	μm	25		30		35		40		50	
Axial runout	μm	25		30		35		40		50	
Max axial load	N	700		1050		2310		2800		11200	
Max moment load	Nm	20		35	45	53	63	72	95	245	
Cont. Current	A rms	6				8		16.2		20	
Peak Current	A rms	18				24		48.6		60	
A5L Model		MDDHT5540L				MFDHTA464L		MFDHTB32A2L			

Application Sample



ATR-IronCore Type



Ironless Type



Frameless Type



IronCore Type

System Configuration

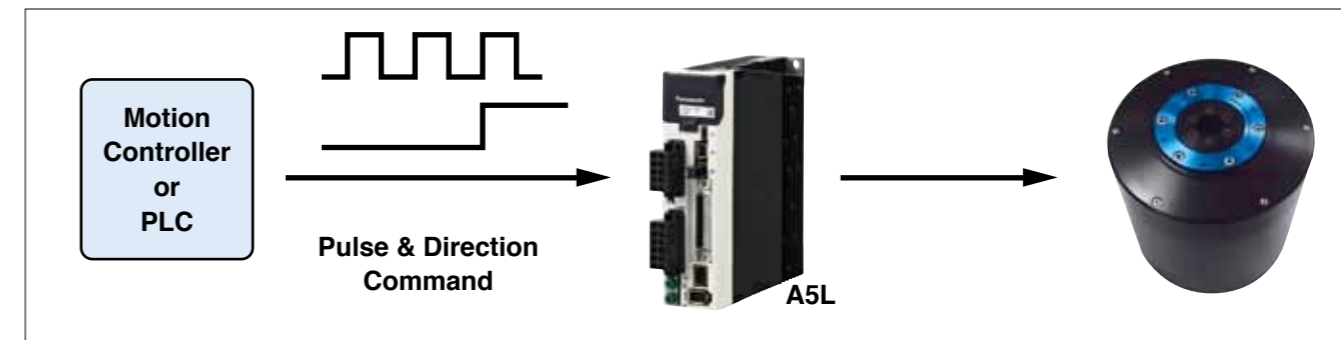
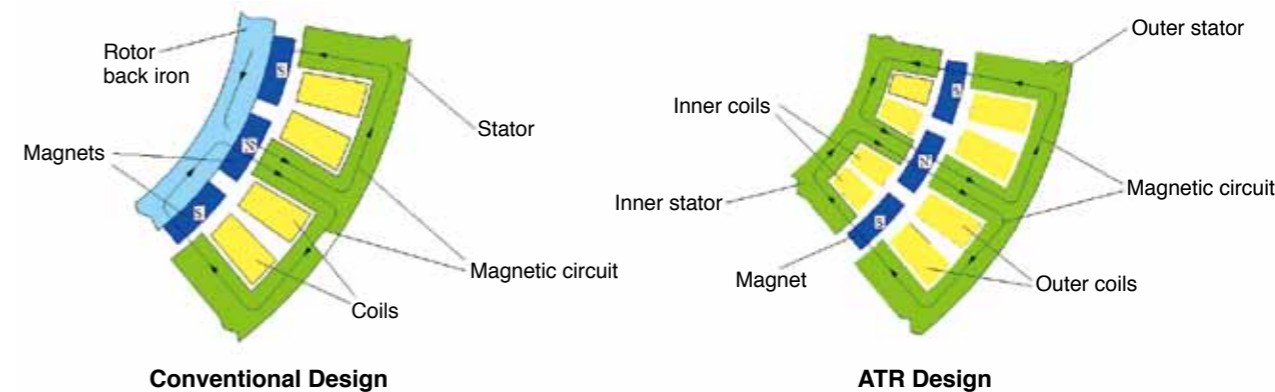

Recommended Drivers:
MCDHT3520***, MDDHT3530***, MDDHT5540***, MEDHT7364***, MFDHTA390***

Sales area and Language



- English
- Chinese
- Korean
- Thai

Please contact the following address for details.

For more information

URL: <http://www.akribis-sys.com/>

Contact: Akribis Systems Pte Ltd

5012 Techplace II Ang Mo Kio Ave 5 #01-05 Singapore 569876

[E-mail: cust-service@akribis-sys.com]

TEL: +65-6484-3357 FAX: +65-6484-3361

Direct Drive Rotary Motors

JTR series

Features

- High precision indexing rotary table
- Minimal cogging design
- High resolution and high torque
- Flexibility in division of angles and control of rotating direction and speed



Specification

PERFORMANCES	UNIT	JTR15T	JTR11 series			JTR15 series			
			JTR1106	JTR1112	JTR1118	JTR1501E	JTR1503E	JTR1505E	JTR1508E
Continuous Torque	N·m	1.4	2	4	6	5	10	18	27
Peak Torque	N·m	4.2	6	12	18	15	30	50	80
Continuous Current	A _{rms}	1.2	1	1	1	1.8	3.7	3.7	3.7
Peak Current	A _{rms}	3.5	3	3	3	5.5	11.1	11.1	11.1
Torque Constant	N·m/A _{rms}	1.2	2	4	6	2.9	2.9	4.9	7.8
Back EMF Constant(ph-ph)	V _{rms} /rad/s	0.7	1.2	2.3	3.5	1.7	1.7	2.8	4.5
Motor Constant	N·m/W ^{1/2}	0.3	0.4	0.6	0.8	0.8	1.3	1.9	2.5
Electrical Time Constant	ms	0.8	1.8	2	2.1	5	6.4	8.1	8.2
Thermal Resistance	°C/W	3.3	4	2.3	1.6	2.2	1.4	1.1	0.7
Max. Speed1)	rps	10	10	8	5	5	5	5	4.5
Resolution2)	ppr	655360	518400			655360			
Accuracy1)	arcsec	±30	±30			±30			
Repeatability1)	arcsec	±2	±2.5			±2			
Axial Run-out (no-load)	μm	20/10/5							
Radial Run-out (no-load)	μm	20/10/5							
Max. Axial Load	kg	120	90	90	90	530	530	530	530
Max. Moment Load	N·m	15	12	12	12	96	96	96	96
Rotor Inertia	kg·m ²	0.00226	0.0007	0.0012	0.0023	0.012	0.021	0.024	0.029
Motor Weight	kg	4.4	3.9	5.4	6.9	6.4	9.8	12.2	15.6
Applicable drive	200 V	MADHT1505L**				MBDHT 2510L**	MCDHT3520L**		
	100 V	MADHT1105L**				MBDHT 2110L**	MCDHT3120L**		

PERFORMANCES	UNIT	JTR16 series		JTR24 series			JTR30 series		
		JTR1604	JTR1608	JTR2403	JTR2408	JTR2413	JTR3015	JTR3030	JTR3045
Continuous Torque	N·m	14	27	10	27	44	50	100	150
Peak Torque	N·m	40	80	30	80	130	150	300	450
Continuous Current	A _{rms}	4.3	9	3.1	4.2	4	4.1	9	9
Peak Current	A _{rms}	12.9	27	9.3	12.6	12	13.6	27.1	28.5
Torque Constant	N·m/A _{rms}	3.1	3	3.3	6.4	11	12.2	11.1	16.7
Back EMF Constant(ph-ph)	V _{rms} /rad/s	1.8	1.7	1.9	3.7	6.4	6.7	6.7	9.6
Motor Constant	N·m/W ^{1/2}	1.3	1.9	1.1	2.2	3.1	3.8	5.4	7.1
Electrical Time Constant	ms	3.5	3.5	6.7	7.4	4.7	8.3	9.1	9.4
Thermal Resistance	°C/W	0.9	0.5	1.1	0.6	0.5	0.54	0.27	0.21
Max. Speed1)	rps	8	9	5	4.5	2.8	2.9	3	2
Resolution2)	ppr	327680		655360			864000		
Accuracy1)	arcsec	±30		±30			±30		
Repeatability1)	arcsec	±4		±2			±2		
Axial Run-out (no-load)	μm	20/10/5							
Radial Run-out (no-load)	μm	20/10/5							
Max. Axial Load	kg	120	120	410	410	410	1100	1100	1100
Max. Moment Load	N·m	15	15	80	80	80	250	250	250
Rotor Inertia	kg·m ²	0.0031	0.0052	0.0092	0.0143	0.0203	0.1004	0.1288	0.1576
Motor Weight	kg	13.9	22	10.7	14.7	19.7	42.7	54.5	66.2
Applicable drive	200 V	MDDHT 3530L**	MDDHT 5540L**	MCDHT3520L**			MDDHT 3530L**	MDDHT5540L**	
	100 V	<input type="checkbox"/>	<input type="checkbox"/>	MCDHT3120L**			<input type="checkbox"/>	<input type="checkbox"/>	

1) Dependent on the encoder resolution. 2) Possible to get more high resolution.

Application Sample

- Alignment and indexing equipment
- Semiconductor test handler
- Glass titler
- Machine tools
- Loader / unloader
- Die bonder, LED handler

Sales area and Language



- Chinese
- Japanese
- English
- Korean

For more information

URL: <http://www.justek.com>

Contact: Justek, Inc.

630-46 Nambudae-ro, Jinwi-myeon, Pyeongtaek, Gyeonggi-do, Korea

[E-mail: info@justek.com]

TEL: +82-31-647-5500 FAX: +82-31-647-5555

Justek, Inc. Japan Branch

WBC 6F, Yokohama World Porters, 2-2-1, Shinkou, Naka-ku, Yokohama, 231-0001, Japan

[E-mail: sjkang@justek.com]

TEL: +81-45-222-2061 FAX: +81-45-222-2061

Coreless Linear Motor Positioning Table

Smart Table DSTN14 Type

Features

- Uses High Performance Neodymium Magnets
- Low velocity ripple & smooth motion with non-cogging coreless motor
- High accuracy with fully closed optical linear encoder feedback
- Thin and compact design
- Independently controlled multiple slider carriages



Specification

No.	Item	Specifications
1	Motor Type	Coreless Synchronous Motor
2	Continuous force (N)	30
3	Peak force (N)	90
4	Continuous current (A rms)	1.5
5	Peak current (A rms)	4.5
6	Table moving mass (kg)	1.7
7	Max. speed (m/s)	2
8	Max. load at 0.5G accel. (kg)	8.6
9	Max. load at 1.0G accel. (kg)	3.5
10	Max. load at 2.0G accel. (kg)	0.9
11	Resolution (μm)	1.0 (Standard) / 0.5 / 0.1
12	Positioning repeatability (μm)	±1
13	Positioning accuracy (μm)	20
14	Standard stroke option (mm)	40, 100, 160, 220, 280, 340, 400, 460, 520, 580, 640, 700, 760, 820, 940, 1060, 1180, 1300, 1420, 1540, 1660, 1780
15	Ambient temperature	0 °C to 40 °C
16	Ambient humidity	20 % to 80 % (Avoid condensation)
17	Standard driver	Panasonic Corp. MINAS A5L (MADHT1107L01)

* Specifications No.2, No.3, No.4, No.5 under following conditions: Ambient temperature at 20 °C, average coil temperature up to 100 °C.

* No.7 max. speed can vary depending on specifications such as stroke and resolution.

* No.12 is the resolution when 1 μm resolution encoder is used.

* No.13 is the accuracy value of 640 mm stroke model.

* Custom stroke models can be manufactured.

* Standard stroke is the distance between limit sensors. Physical stroke limit between mechanical stoppers is std stroke+20 mm.

* Conditions for No.8 to 10: cycle = [accel. → max. speed → decel. → rest],

max. speed = 2 m/s, accel. time = decel. time, max. speed time = 2x accel. time, rest time = max. speed time.

Application Sample

- Laser application machine
- Semiconductor equipment
- Industrial robot
- Automatic fabricating machine
- Motion picture camera
- Various electronic parts manufacturing machine in chamber
- Measuring instrument

System Configuration

Standard Stroke Se (mm)	Physical Stroke Sl (mm)	L (mm)	M	N (mm)	Table Mass (kg)
40	60	250	1	50	8.5
100	120	310	1	80	10.0
160	180	370	2	35	11.0
220	240	430	2	65	12.5
280	300	490	3	20	13.5
340	360	550	3	50	15.0
400	420	610	3	80	16.0
460	480	670	4	35	17.5
520	540	730	4	65	18.5
580	600	790	5	20	20.0
640	660	850	5	50	21.0

Standard Stroke Se (mm)	Physical Stroke Sl (mm)	L (mm)	M	N (mm)	Table Mass (kg)
700	720	910	5	80	22.5
760	780	970	6	35	23.5
820	840	1030	6	65	25.0
940	960	1150	7	50	27.5
1060	1080	1270	8	35	30.0
1180	1200	1390	9	20	32.0
1300	1320	1510	9	80	35.0
1420	1440	1630	10	65	37.0
1540	1560	1750	11	50	40.0
1660	1680	1870	12	35	42.0
1780	1800	1990	13	20	45.0

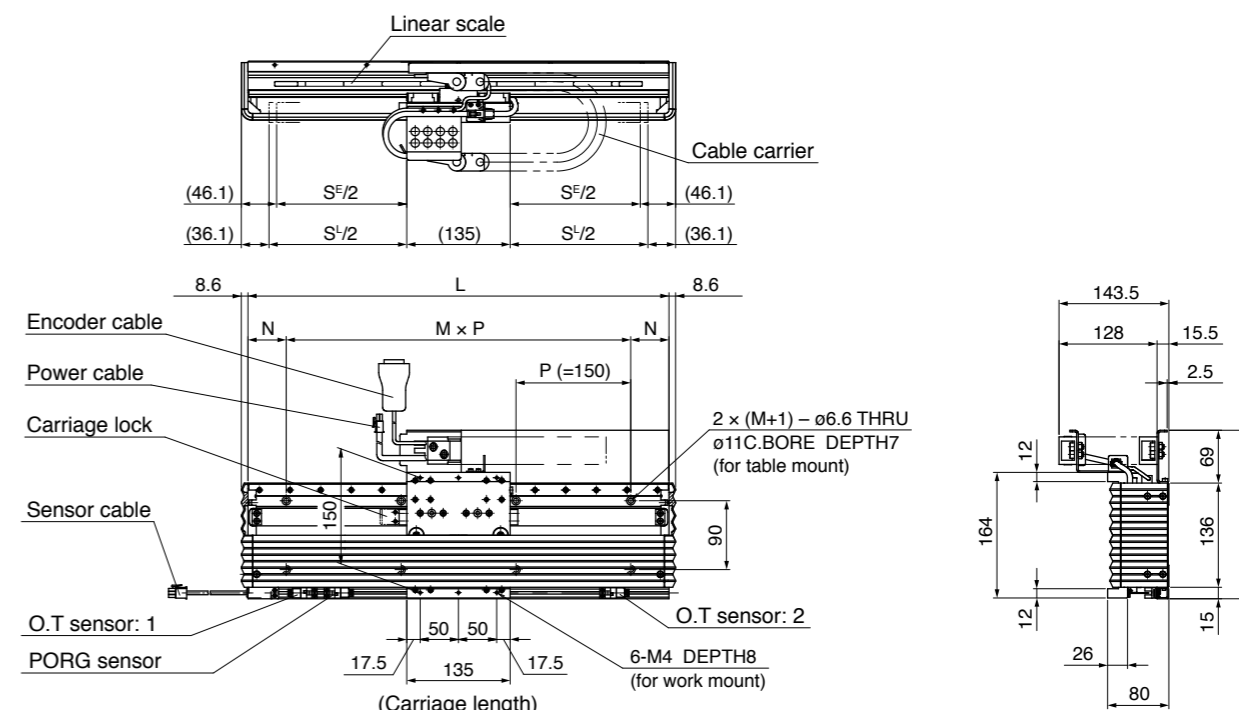

Sales area and Language



- Japanese
- English

Please contact the following address for details.

For more information

URL: <http://www.nb-linear.co.jp/>

Contact: **NIPPON BEARING CO.,LTD.**

2833 Chiya,Ojiya-city, Niigata-pref, 947-8503, Japan

[E-mail: info@nb-linear.co.jp]

TEL: +81-258-82-0011 FAX: +81-258-81-1135

Linear Shaft Motor

S series/L series

Features

- Coreless Technology
- Zero Cogging
- High Force and High Precision
- Energy Efficient
- Simple Design and Easy Integration

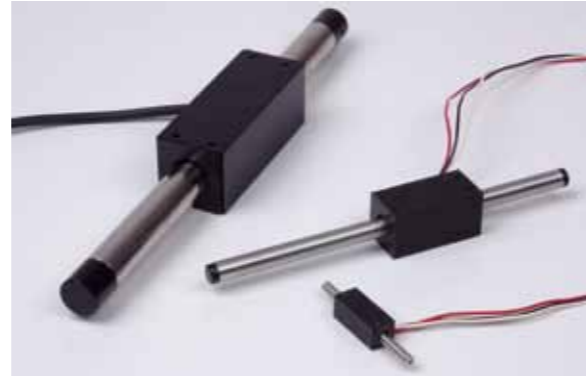

Specification

	Units	S080 series			S120 series			S160 series			S200 series			S250 series		
		S080D	S080T	S080Q	S120D	S120T	S120Q	S160D	S160T	S160Q	S200D	S200T	S200Q	S250D	S250T	S250Q
Shaft Diameter	mm	8	8	8	12	12	12	16	16	16	20	20	20	25	25	25
Stroke Length Range	mm	25~300	25~300	25~300	50~1750	50~1750	50~1750	100~1750	100~1750	100~1750	100~2700	100~2700	100~2700	100~2550	100~2550	100~2550
Continuous Force	N	1.8	2.7	3.5	4.5	6.6	8.9	10	15	20	18	28	38	40	60	75
Continuous Current	A rms	0.84	0.84	0.84	0.4	0.4	0.4	0.62	0.62	0.62	0.59	0.59	0.59	1.28	1.28	1.28
Peak Force	N	7.2	10.7	14	18	27	36	40	60	81	72	112	152	160	240	300
Peak Current	A rms	3.4	3.4	3.4	1.6	1.6	1.6	2.5	2.5	2.5	2.4	2.4	2.4	5.1	5.1	5.1
Magnet Pitch N-N	mm	30	30	30	48	48	48	60	60	60	72	72	72	90	90	90
Gap	mm	0.5	0.5	0.5	0.5	0.5	0.5	0.5	0.5	0.5	0.75	0.75	0.75	0.75	0.75	0.75
A5L Model	200 V	MADHT1505LXX									MADHT1507LXX					
	100 V	MADHT1105LXX									MADHT1107LXX					

	Units	S320 series			S350 series			S427 series			S435 series			S500 series		
		S320D	S320T	S320Q	S350D	S350T	S350Q	S427D	S427T	S427Q	S435D	S435T	S435Q	S500D	S500T	S500Q
Shaft Diameter	mm	32	32	32	35	35	35	42.7	42.7	42.7	43.5	43.5	43.5	50	50	50
Stroke Length Range	mm	100~2700	100~2700	100~2700	100~2500	100~2500	100~2500	100~3600	100~3600	100~3600	100~2600	100~2600	100~2600	100~3850	100~3850	100~3850
Continuous Force	N	56	85	113	104	148	190	100	150	200	116	175	233	289	440	585
Continuous Current	A rms	1.22	1.17	1.15	1.5	1.5	2.7	3	3	3	3	3	3	3.8	5.8	7.7
Peak Force	N	226	338	451	416	592	760	400	600	800	464	700	932	1156	1760	2340
Peak Current	A rms	5	5	5	6	6	10.8	12	12	12	12	12	12	15.2	23.2	30.8
Magnet Pitch N-N	mm	120	120	120	120	120	120	180	180	180	180	180	180	180	180	180
Gap	mm	1.0	1.0	1.0	1.0	1.0	1.0	1.65	1.65	1.65	1.25	1.25	1.25	1.75	1.75	1.75
A5L Model	200 V	MADHT1507LXX			MADHT1507LXX			MCDHT3520LXX	MCDHT3520LXX					MDDHT5540LXX		
	100 V	MADHT1107LXX			MADHT1107XX			MCDHT3120LXX	MCDHT3120LXX					—		

Model Number	Units	S605 series		L250 series			L350 series		
		S605T	S605Q	L250D	L250T	L250Q	L320D	L320T	L320Q
Shaft Diameter	mm	60.5	60.5	25	25	25	32	32	32
Stroke Length Range	mm	100~3850	100~3850	100~3650	100~3650	100~3650	100~3600	100~3600	100~3600
Continuous Force	N	610	780	34	52	69	55	82	109
Continuous Current	A rms	8.6	8.4	1.3	1.3	1.3	1.25	1.25	1.25
Peak Force	N	2400	3100	138	207	276	218	327	436
Peak Current	A rms	34	34	5.2	5.2	5.2	5	5	5
Magnet Pitch N-N	mm	240	240	90	90	90	120	120	120
Gap	mm	1.75	1.75	2	2	2	2.5	2.5	2.5
A5L Model	200 V	MDDHT5540LXX		MADHT1507KXX					
	100 V	—		MADHT1107LXX					

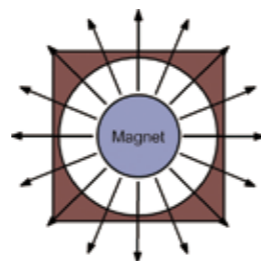

Application Sample

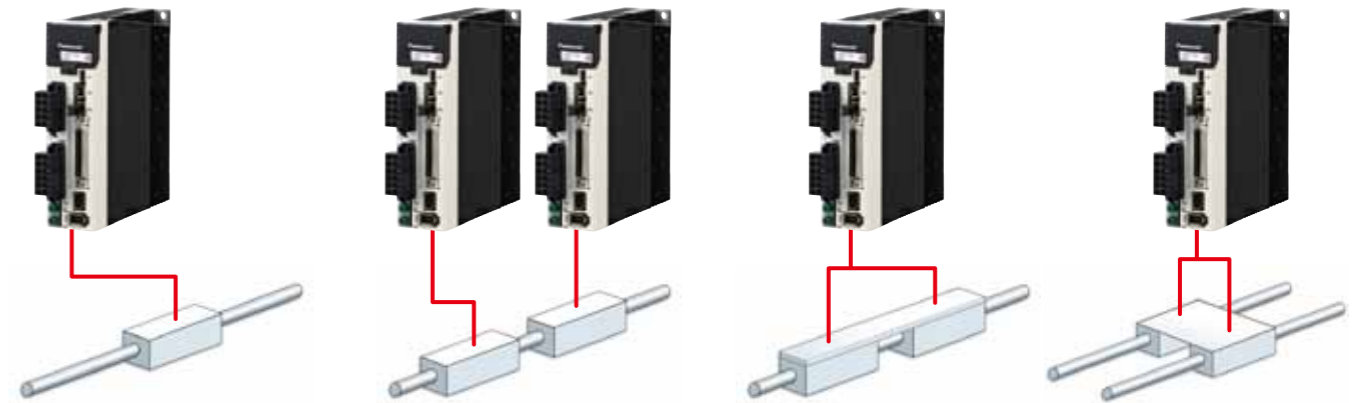

Constuction

- Simple
- High Precision
- Non Contact

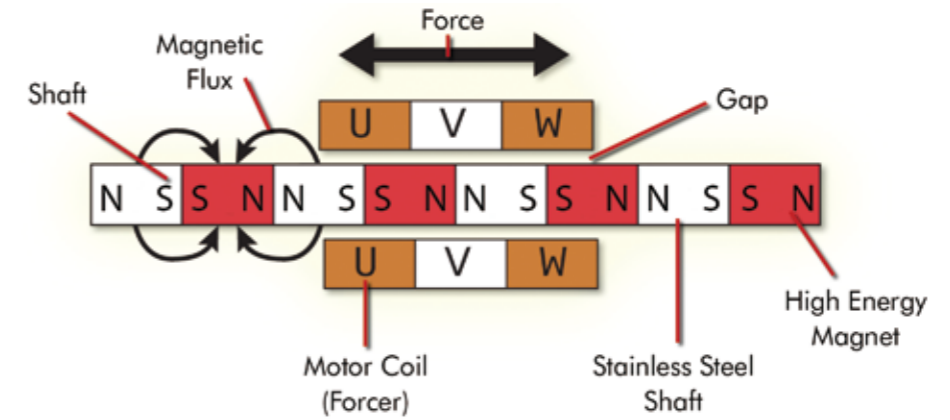

Sales area and Language



- English
- Japanese
- Chinese

Please contact the following address for details.

For more information

URL: <http://nipponpulse.com/products/overview/linear-shaft-servomotors/>

Contact: **Nippon Pulse America., Inc.**

4 Corporate Drive, Radford, Virginia 24141 U.S.A.

[E-mail: info@nipponpulse.com]

TEL: +1-540-633-1677 / +1-540-633-1674

Linear Shaft Motor Stage

SLP series / SCR series

Features

SLP-series

- High Force
- High Speed



SCR-series

- High Precision
- Low Ripple at Low Speed
- High Repeatability



Specification

	Units	SLP series			SCR series	
		SLP15	SLP25	SLP35	SLR075	SCR100
Resolution	μm	1 (Hidenhain LIDA279)	1 (Hidenhain LIDA279)	1 (Hidenhain LIDA279)	1, 0.5, 0.1, 0.05, 0.01 (Renishaw Tonic)	1, 0.5, 0.1, 0.05, 0.01 (Renishaw Tonic)
Stroke/Single Slider	mm	100 to 1300 (100 interval)	200 to 1200 (100 interval)	200 to 1200 (100 interval)	50, 100, 150	50 to 300 (50 interval)
Strike/ Double Slider	mm	100 to 1200 (100 interval)	200 to 1000 (100 interval)	300 to 900 (100 interval)	-	-
Continuous Force	N	17	80	185	3.5	3.5
Continuous Current	A rms	0.51	1.2	2.7	0.84	0.84
Peak Force	N	90	340	970	14	14
Peak Current	A rms	2.7	5.1	14.4	3.4	3.4
Max. Velocity	m/sec	3.0	3.0	3.0	1.1 to 1.5 (depends)	0.9 to 1.3 (depends)
Resistance	Ω	56	22	22	9.0	9.0
Inductance	mH	24	31	12	1.3	1.3
Magnet Pitch N-N	mm	60	90	120	30	30
Load Capacity	kg	3	15	30	45.5	45.5
Panasonic A5L	200 V	MADHT1505LXX	MADHT1507KXX	MCDHT3520LXX	MADHT1505LXX	MADHT1505LXX
	100 V	MADHT1105L	MADHT1107LXX	MCADHT3120LXX	MADHT1105LXX	MADHT1105LXX

Application Sample



Customized SCR stage



Construction

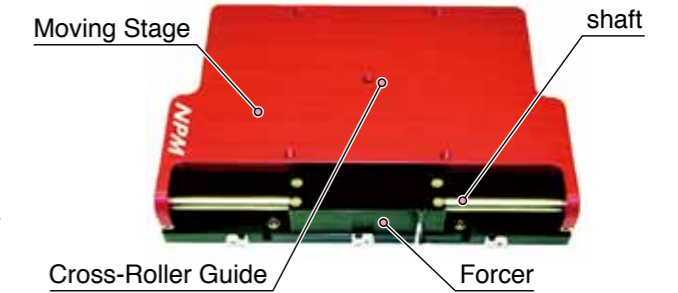
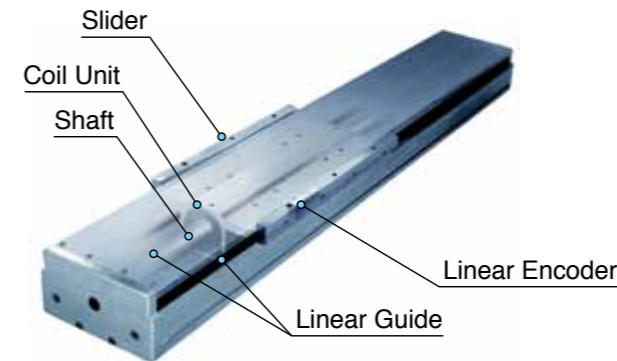

Sales area and Language



- English
- Japanese
- Chinese

Please contact the following address for details.

For more information

<SLP series>

URL: <http://nipponpulse.com/products/overview/slp-stage/>

<SCR series>

URL: <http://nipponpulse.com/products/overview/linear-shaft-stages>

Coreless and Core Linear Motor

U-Coreless/T-Core/Platen-Core Type

Features

U-Coreless Type



- No Cogging
- No Magnetic Attraction Force
- Fast Setting-time Response
- Easy to install

T-Core Type



- Cogging Optimization
- High-density Force & Attraction Force
- No normal Force
- Easy to install

Platen-Core Type



- Cogging Optimization
- High-density Force & Attraction Force
- Most economic design solution
- Easy to install

Specification

Item	Model	Dimension [mm]	Continu. Force [N]	Continu. Current [Arms]	Max. Force [N]	Max. Current [Arms]	Back EMF [Vrms/m/sec]	Force Constant [N/Arms]	Magnetic Attraction [N]	Resistance [Ohm]	Inductance [mH]	Weight [kg]	Motor Constant [N/sqrt(W)]	Thermal Resistance [°C/W]	Pole-Pitch (N to S) [mm]	Max Velocity [m/sec]	Carrier f : 6KHz	Carrier f : 12KHz
U-Coreless (Tiny)	ML-ULT-1SA*	80(L)x37(W)x77.5(H)	21	1.39	63	4.17	5.3	15.3	0	3.3	1.7	0.3	4.29	2.51	15.00	17.3		MADHT1507L01
	ML-ULT-2SA*	140(L)x37(W)x77.5(H)	43	1.39	129	4.17	10.7	30.8	0	6.6	3.4	0.6	6.22	1.25	15.00	7.2		MADHT1507L01
	ML-ULT-3SA*	200(L)x37(W)x77.5(H)	64	1.39	192	4.17	16	46.1	0	9.9	5.1	0.9	7.56	0.84	15.00	3.6		MADHT1507L01
	ML-ULT-2S2PA*	260(L)x37(W)x77.5(H)	86	2.79	258	8.37	10.7	30.8	0	3.3	1.7	1.1	8.76	0.62	15.00	7.2	MCDHT3520L01	MDDHT3530L01
U-Coreless (Small)	ML-ULS-3SA*	202(L)x38.4(W)x92(H)	97	3.26	292	9.78	10.4	30.0	0	2.0	1.2	0.8	10.86	0.75	15.00	7.3	MCDHT3520L01	MDDHT3530L01
	ML-ULS-4SA*	262(L)x38.4(W)x92(H)	130	3.26	390	9.78	13.8	39.7	0	2.6	1.7	1.1	12.77	0.58	15.00	5.1	MCDHT3520L01	MDDHT3530L01
	ML-ULS-5SA*	322(L)x38.4(W)x92(H)	162	3.26	486	9.78	17.3	49.8	0	3.3	2.1	1.4	14.13	0.46	15.00	3.7	MCDHT3520L01	MDDHT3530L01
	ML-ULS-6SA*	382(L)x38.4(W)x92(H)	195	3.26	585	9.78	20.8	59.9	0	3.9	2.5	1.6	15.64	0.39	15.00	2.8	MCDHT3520L01	MDDHT3530L01
	ML-ULS-7SA	442(L)x38.4(W)x92(H)	227	3.26	681	9.78	24.2	69.7	0	4.6	2.9	1.9	16.77	0.33	15.00	2.1	MCDHT3520L01	MDDHT3530L01
U-Coreless (Medium)	ML-ULM-1SA(S)	120(L)x47.4(W)x121.5(H)	85	3.00	254	9.00	9.8	28.2	0	0.85	2.05	0.7	15.78	2.09	22.50	11.0	MCDHT3520L01	MDDHT3530L01
	ML-ULM-2SA(S)	210(L)x47.4(W)x121.5(H)	169	3.00	507	9.00	19.6	56.4	0	1.70	4.10	1.4	22.31	1.05	22.50	4.6	MCDHT3520L01	MDDHT3530L01
	ML-ULM-3SA*	300(L)x47.4(W)x121.5(H)	254	3.00	762	18.00	14.7	42.3	0	1.30	3.10	2.0	19.17	0.34	22.50	6.4	MDDHT5540L01	MEDHT7364L01
	ML-ULM-4SA*	390(L)x47.4(W)x121.5(H)	338	6.00	1014	18.00	19.6	56.4	0	1.70	4.10	2.7	22.31	0.26	22.50	4.6	MDDHT5540L01	MEDHT7364L01
	ML-ULM-5SA*	480(L)x47.4(W)x121.5(H)	424	6.00	1272	18.00	24.5	70.6	0	2.10	5.10	3.3	25.18	0.21	22.50	3.6	MDDHT5540L01	MEDHT7364L01
U-Coreless (Large)	ML-Ull-3PA*	397(L)x50.4(W)x152(H)	506	7.16	1518	21.48	24.6	70.7	0	1.3	2.9	3.4	32.01	0.24	30.00	2.8	MDDHT3530L01	MDDHT5540L01
	ML-Ull-4PA*	517(L)x50.4(W)x152(H)	675	9.55	2025	28.65	24.6	70.7	0	1.0	2.2	4.5	36.50	0.18	30.00	2.8	MDDHT5540L01	MEDHT7364L01
	ML-Ull-5PA*	637(L)x50.4(W)x152(H)	844	11.94	2531	35.81	24.6	70.7	0	0.8	1.8	5.6	40.81	0.14	30.00	2.8	MDDHT5540L01	MEDHT7364L01
U-Coreless (X-large)	ML-ULX-2PA*	336(L)x66.6(W)x224(H)	771	7.40	2313	22.20	36.2	104.2	0	1.4	4.6	5.5	45.47	0.21	37.50	2.0	MDDHT5540L01	MEDHT7364L01
	ML-ULX-3PA*	486(L)x66.6(W)x224(H)	1157	11.10	3471	33.30	36.2	104.2	0	1.0	3.1	8.3	53.83	0.13	37.50	2.0	MEDHT7364L01	MFDHTA390L01
	ML-ULX-4PA*	636(L)x66.6(W)x224(H)	1542	14.80	4626	44.40	36.2	104.2	0	0.7	2.3	11.1	64.31	0.10	37.50	2.0	MFDHTA390L01	MFDHTB3A2L01
T-Core (Tiny)	ML-TCT-1P	101(L)x38.7(W)x67.5(H)	118	1.3	354	3.9	30.7	92.1	0	17.3	56.4	2.2	13.61	0.80	22.50	2.1		MADHT1507L01
	ML-TCT-2P	191(L)x38.7(W)x67.5(H)	236	2.6	708	7.8	30.7	92.1	0	8.7	28.2	4.5	19.25	0.40	22.50	2.1	MBDHT2510L01	MCDHT3520L01
	ML-TCT-3P	281(L)x38.7(W)x67.5(H)	354	3.9	1062	11.7	30.7	92.1	0	5.8	18.8	6.7	23.57	0.27	22.50	2.1	MDDHT3530L01	MDDHT5540L01
	ML-TCT-4P	371(L)x38.7(W)x67.5(H)	472	5.2	1416	15.6	30.7	92.1	0	4.3	14.1	8.9	27.22	0.20	22.50	2.1	MDDHT3530L01	MDDHT5540L01
T-Core (Medium)	ML-TCM-2P	191(L)x72.3(W)x135(H)	550	4.5	1650	13.5	37.76	113.3	0	2.0	17.3	4.5	44.85	0.40	22.50	2.0	MDDHT3530L01	MDDHT5540L01
	ML-TCM-3P	281(L)x72.3(W)x135(H)	825	6.8	2475	20.3	37.76	113.3	0	1.3	11.6	6.7	54.93	0.27	22.50	2.0	MDDHT5540L01	MEDHT7364L01
	ML-TCM-4P*	371(L)x72.3(W)x135(H)	1100	9.0	3300	27.0	37.76	113.3	0	1.0	8.7	8.9	63.43	0.20	22.50	2.0	MDDHT5540L01	MEDHT7364L01
	ML-TCM-5P	461(L)x72.3(W)x135(H)	1375	11	4125	34	37.76	113.3	0	0.8	6.9	11.1	70.92	0.16	22.50	2.0	MEDHT7364L01	MFDHTA390L01
	ML-PCT-1SF*	69(L)x55(W)x45(H)	43	1.44	129	4.32	14.6	29.8	192.0	3.4	17.5	0.7	8.42	2.30	15.00	7.30		MADHT1507L01
Platen Core (Tiny)	ML-PCT-2SF*	129(L)x55(W)x45(H)	86	1.44	258	4.32	29.2	59.5	384.0	6.7	35.1	1.4	11.91	1.15	15.00	3.10		MADHT1507L01
	ML-PCT-3SF	189(L)x55(W)x45(H)	129	1.44	387	4.32	43.8	89.3	576.0	10.1	52.6	2.1	14.59	0.77	15.00	1.60		MADHT1507L01
	ML-PCT-2S2PF	249(L)x55(W)x45(H)	172	2.88	516	8.64	29.2	59.5	768.0	3.4	17.5	2.8	16.85	0.58	15.00	3.10	MCDHT3520L01	MDDHT3530L01
Platen Core (Small)	ML-PCS-1SE	69(L)x75(W)x46.3(H)	80	2.30	240	6.90	11.6	34.8	320.0	1.4	11.3	0.8	15.18	2.16	15.00	9.00	MBDHT2510L01	MDDHT3520L01
	ML-PCS-2SE*	129(L)x75(W)x46.3(H)	150	2.25	450	6.75	23.2	69.6	640.0	2.8	22.6	1.6	20.57	1.13	15.00	3.70	MBDHT2510L01	MDDHT3520L01
	ML-PCS-3SE*	189(L)x75(W)x46.3(H)	225	2.25	675	6.75	34.8	104.4	960.0	4.1	33.9	2.4	25.50	0.77	15.00	2.10	MBDHT2510L01	MDDHT3520L01
	ML-PCS-2S2PE*	249(L)x75(W)x46.3(H)	300	4.5	900	13.50	23.2	69.6	1280.0	1.4	11.3	3.2	29.10	0.56	15.00	3.70	MDDHT3530L01	MDDHT5540L01
Platen Core (Large)	ML-PCL-2PE*	251(L)x133(W)x58(H)	670	6.2	2000	18.60	37	111	3200.0	1.2	5.9	6.8	50.94	0.35	30.00	2.3	MDDHT5540L01	MEDHT7364L01
	ML-PCL-3PE*	371(L)x133(W)x58(H)	1000	9.29	3000	27.87	37	111	4800.0	0.8	4.0	10.2	62.15	0.23	30.00	2.3	MEDHT7364L01	MFDHTA390L01

Application Sample

X-Y Gantry



For Heavy duty Industrial Equipment

Compact X-Y Table

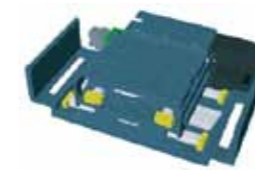

Has enough stroke even in a small area

High Precision Air-Bearing Stage



Air Bearing is applied for non-touching moving structure

Multi-Mover Linear Stage



4sets of independent driving Linear Motor applied in a single line

Selection Guide

Mover The moving parts are made up of the coll, Frame, and Epoxy Mold

ML - PCL - 2S2PE
① ② ③ ④ ⑤ ⑥

① Shape	② Core	③ Magnet size	④ Number of Serial Coil	⑤ Number of Parallel Coil	⑥ Design oder
U : U shape T : T shape P : Platen	C : Core type L : Core-less	T : Tiny S : Small M : Medium L : Large X : X-Large	1S : 1 serial 2S : 2 serial 3S : 3 serial ...	1P : 1parallel 2P : 2parallel 3P : 3parallel ...	A, B, C, D, E, ...

Stator The fixed parts are made up of the Magnet and the Back Iron

ML - PCL - SE - 540
① ② ③ ④ ⑤

① Shape	② Core	③ Magnet size	④ Stator Design Oderl	⑤ Stator Length
U : U shape T : T shape P : Platen	C : Core type L : Core-less	T : Tiny S : Small M : Medium L : Large	SA, AB, SC, ...	270 : 270 mm 330 : 330 mm 540 : 540 mm

Stators Specification

Item	Model	Length [mm]	Item	Model	Length [mm]	Item	Model	Length [mm]	Item	Model	Length [mm]
U-Shape Coreless (Tiny model)	ML-ULT-SA-240	240	U-Shape Coreless (Large model)	ML-Ull-SA-180	180	T-Shape Core Type (Tiny model)	ML-TCT-SA-270	270	Platen Core Type (Tiny model)	ML-PCT-SE-120	120
	ML-ULT-SA-360	360		ML-Ull-SA-300	300		ML-TCT-SA-360	360		ML-PCT-SE-180	180
	ML-ULT-SA-480	480		ML-Ull-SA-480	480		ML-TCT-SA-540	540		ML-PCT-SE-240	240
U-Shape Coreless (Small model)	ML-ULS-SA-360	360	U-Shape Coreless (X-large model)	ML-Ull-SA-600	600	T-Shape Core Type (Medium model)	ML-TCM-SA-270	270	Platen Core Type (Small model)	ML-PCM-SA-270	270
	ML-ULS-SA-420	420		ML-Ull-SA-150	150		ML-TCM-SA-360	360		ML-PCT-SE-360	360
	ML-ULS-SA-480	480		ML-Ull-SA-300	300		ML-TCM-SA-450	450		ML-PCT-SE-420	420
U-Shape Coreless (Medium model)	ML-Ull-SA-600	600	U-Shape Coreless (X-large economic)	ML-Ull(e)-SA-600	600	Platen Core Type (Large model)	ML-TCM-SA-495	495	ML-PCL-SE-120*	120	
	ML-Ull(e)-SA-150	150		ML-Ull(e)-SA-150	150		ML-TCM-SA-540	540		ML-TCM-SA-630	630
	ML-Ull(e)-SA-300	300		ML-Ull(e)-SA-300	300		ML-TCM-SA-720	720		ML-TCM-SA-945	945
U-Shape Coreless (Medium economic)	ML-Ull(e)-SA-270	270									
	ML-Ull(e)-SA-360	360									
	ML-Ull(e)-SA-450	450									
U-Shape Coreless (Medium economic)	ML-Ull(e)-SA-540	540									
	ML-Ull(e)-SA-630	630									
	ML-Ull(e)-SA-630	630									

* special

Sales area and Language



- Korea : +82-70-8230-8770
- English : +82-70-8230-8771
- Chinese : +86-138-2520-1988

For more information

Coreless Linear Motor, Ironcore Linear Motor, Special Sodick V series

Features

In linear motors that will be assembled at the internal of machine tools, the generated heat must not influence the machine. Sodick linear motors have special cooling structure internal. And, In servo motors that will be assembled at the side of machine tools, the generated heat influence the machine a little.

Coreless Linear Motors

CA SERIES 144N-576N
CB SERIES 1200N-2133N
CG SERIES 3432N-4800N



Ironcore Linear Motors

CM SERIES 190N-1172N
CE (M) 800N-1600N CE (L) 1600N-6400N
CE (W) 4800N-7200N CE (W2) 6400N-9600N



Internal cooling structure * Patented in JAPAN, USA, CHINA

Special Motors

Sodick performs the design of a special motor according to a customer's demand.



← Circular Arc Motors

DD motor and the circular arc motor of ironcore and coreless motors are designed by Sodick.

Ultra Vacuum Linear Motors →

The linear motor corresponding to the vacuum of Sodick is equipped with the system which can be efficiently cooled also in a vacuum.



The configuration example of a linear motor system

Network Servo System by Panasonic A5NL

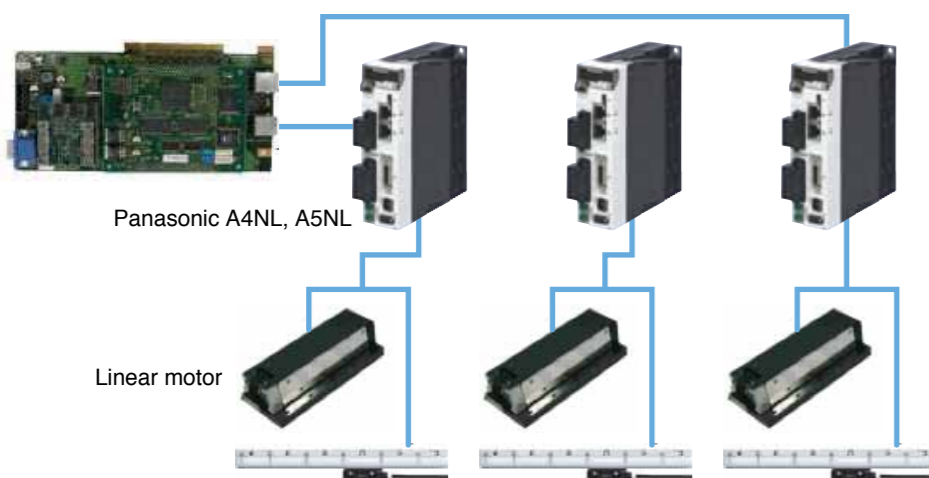

Serial & Analog I/F by A5L

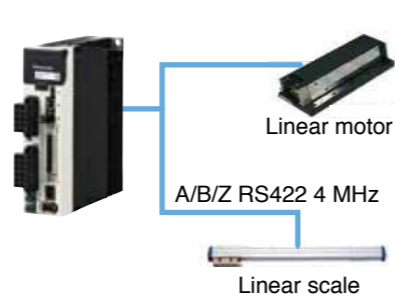

Specification

● Coreless Linear Motor CA Series

Motor Type	Name	CA010*(V)			CA020*(V)			CA030*(V)			CA040*(V)		
		A Oil	B None	D Water	A Oil	B None	D Water	A Oil	B None	D Water	A Oil	B None	D Water
Amplifier [12 kHz]		MCDHT3520L			MDDHT5540L			MEDHT7364L			MEDHT7364L		
Cont. FORCE	N	48	16.8	60	96	36	120	134.4	55.2	168	176	72	220
Max. FORCE	N	144			288			432			576		
Rated SPEED	m/sec	7			7			7			7		
Max. SPEED	m/sec	7			7			7			7		
SIZE (D x W x L)	mm	30 x 110 x 130			30 x 110 x 202			30 x 110 x 274			30 x 110 x 346		
WEIGHT	kg	0.5	0.5	0.8	0.8	0.8	1.1	1.1	1.1	1.4	1.4	1.4	1.8

● Coreless Linear Motor CB Series

Motor Type	Name	CB100		CB110		CB160i		CB200i	
		None	Water	None	Water	None	Water	None	Water
Amplifier [6 kHz]		MDDHT5540L		MDDHT5540L		MEDHT7364L		MFDHTA390L	
Cont. FORCE	N	135	350	139	406	188	536	251	744
Max. FORCE	N	1200		1392		1600		2133	
Rated SPEED	m/sec	2.5		1.8		2.7		2.7	
Max. SPEED	m/sec	4		3.6		3		3	
SIZE (D x W x L)	mm	50 x 165 x 303		50 x 165 x 303		50 x 165 x 303		50 x 165 x 375	
WEIGHT	kg	3.5		3.6		3.9		5.0	

● Coreless Linear Motor CG Series

Motor Type	Name	CG300		CG400	
		None	Water	None	Water
Amplifier [6 kHz]		MFDHTB3A2L		MGDHTC3B4L	
Cont. FORCE	N	520	1000	700	1300
Max. FORCE	N	3432		4800	
Rated SPEED	m/sec	1.5		1.5	
Max. SPEED	m/sec	2.4		2.4	
SIZE (D x W x L)	mm	62 x 240 x 478		62 x 240 x 595	
WEIGHT	kg	13.3		17.3	

● Ironcore Linear Motor CM Series

Motor Type	Name	CM003(V)		CM007(V)		CM010(V)		CM020(V)	
		None	Fin	None	Fin	None	Fin	None	Fin
Amplifier [6 kHz]		MBDHT2510L		MDDHT3530L		MDDHT5540L		MEDHT7364L	
Cont. FORCE	N	28	41	58	86	89	132	178	264
Max. FORCE	N	160		390		600		1200	
Rated SPEED	m/sec	2.2		2.2		2.2		2.2	
Max. SPEED	m/sec	5		5		5		5	
SIZE (D x W x L)	mm	41 x 50 x 115		41 x 75 x 115		41 x 100 x 115		41 x 100 x 211	
WEIGHT	kg	0.9		1.3		1.7		3.4	

● Ironcore Linear Motor CE(M) Series

Motor Type	Name	CE033			CE066L		
		Oil	None	Water	Oil	None	Water
Amplifier [6 kHz]		MDDHT5540L			MFDHTB3A2L		
Cont. FORCE	N	400	200	500	800	400	1000
Max. FORCE	N	800			1600		
Rated SPEED	m/sec	4			4		
Max. SPEED	m/sec	6			6		
SIZE (D x W x L)	mm	60 x 81 x 244 (75 x 125 x 247)			60 x 81 x 433 (75 x 125 x 436)		
WEIGHT	kg	7.5			13.8		

● Ironcore Linear Motor CE(L) Series

Motor Type	Name	CE066			CE133			CE200			CE266		
		Oil	None	Water	Oil	None	Water	Oil	None	Water	Oil	None	Water
Amplifier [6 kHz]		MEDHT7364L			MFDHTB3A2L			MGDHTC3B4L			MHDHTC3B4L		
Cont. FORCE	N	870	390	900	1740	780	2000	2610	1170	3000	3480	1560	4000
Max. FORCE	N	1600			3200			4800			6400		
Rated SPEED	m/sec	2			2			2			2		
Max. SPEED	m/sec	3			3			3			3		
SIZE (D x W x L)	mm	63 x 150 x 244 (78 x 160 x 247)			63 x 150 x 465 (78 x 160 x 471)			63 x 150 x 641 (78 x 160 x 647)			63 x 150 x 854 (83 x 160 x 860)		
WEIGHT	kg	12			24			33			42		

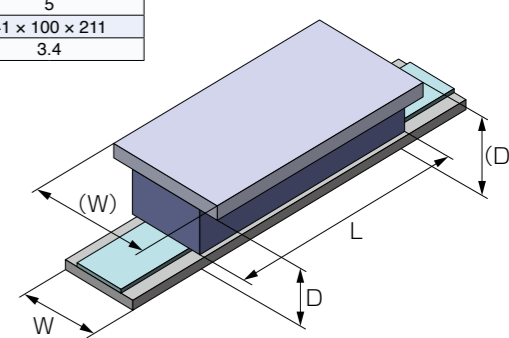
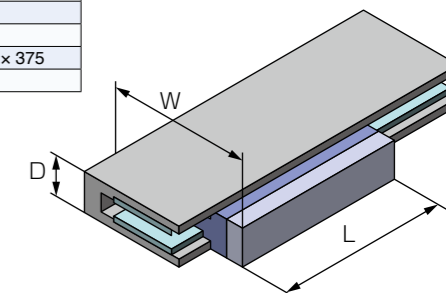

LINEAR MOTOR and DIRECT DRIVE MOTOR

Sales area and Language



- English
- Chinese
- Japanese

Please contact the following address for details.

For more information

URL: <http://www.sodick.jp/>

Contact: **Sodick Co., Ltd.**

3-12-1 Nakamachidai, Tsuzuki-ku, Yokohama-city, Kanagawa-Pref. 224-8522, Japan TEL: +81-45-948-1403 FAX: +81-45-941-5271

Linear Encoder

SAP/GAP series/ LAP series/ EXA/EXG/EXT series

Features

- Extremely robust optoelectronic linear encoders.
- Connectivity to MINAS series drives.
- Great accuracy at high speeds.
- Longest absolute measuring length available up to 30 m.
- Enclosed and exposed families available.
- Advanced diagnosis tool, via PC connection.

ABS glass

SAP and GAP series
(MINAS A4, A5 and A5L)



ABS steel tape

LAP series
(MINAS A4, A5 and A5L)



INC steel tape exposed

EXA, EXG, EXT series
(MINAS A5, A5L)



Specification

Item	Description			
Measuring standard	Glass scale with absolute and incremental track *		Steel tape scale with absolute and incremental track *	
Valid for Panasonic models	A5, A5L			
Linear scale model	SAP	SVAP	GAP	LAP
Resolution	0.05 μm or 0.01 μm			0.10 μm or 0.01 μm
Max. Length	1240 mm	2040 mm	3040 mm	30 m
Accuracy	±3 μm / ±5 μm			±5 μm
Max. Travel speed	3 m/s			2 m/s
Vibration / shock	10 G/ 30 G	20 G/ 30 G	20 G/ 30 G	10 G/ 30 G
Coef. Linear expansion	(8±0.5) × 10 ⁻⁶ /°C			(11±0.5) × 10 ⁻⁶ /°C
Operating / storage temperature	0 °C to 50 °C/ -20 °C to 70 °C			
Protection	IP 53 as standard. When using air purge system IP 64			
Power supply	DC 5 V ± 10 %			
Current consumption	250 mA			

Item	Description		
Measuring standard	Steel tape scale with absolute and incremental track *		
Valid for Panasonic models	A5, A5L		
Linear scale model	EXA	EXG	EXT
Resolution	Up to 1 μm		
Max. Length	16040 mm	6040 mm	30040 mm
Accuracy	±10 μm (without compensation)		±5 μm (without compensation)
Max. Travel speed	8 m/s		
Max. Cable length	100 m		
Signals type	1 Vpp (sinewave) or TTL (squarewave)		
Max. Frequency	400 kHz with 1 Vpp / 1 MHz with TTL		
Power supply	DC 5 V ± 10 %		

* For incremental, A/B phase type is only available.

Application Sample

For SAP/SVAP/GAP/LAP Series

- Milling machines
- Machining centres
- Turning machines
- Grinding machines
- Gear hobbing machines
- Special purpose machines

For EXA/EXG/EXT Series

- Linear motors
- Coordinated measuring machines
- Semiconductors
- Motion control
- PCB drilling machines
- Pick and place
- Visual inspection

System Configuration

For SAP/SVAP/GAP/LAP Series

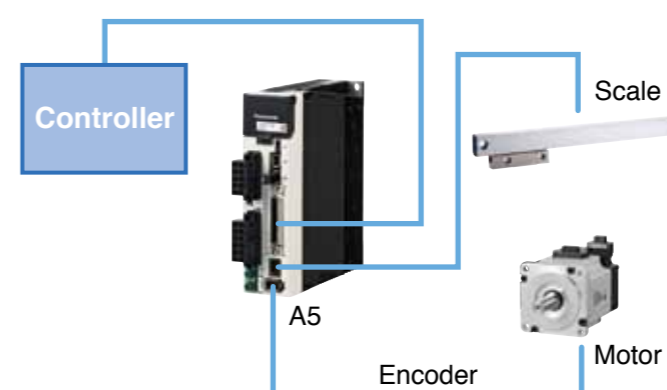

For EXA/EXG/EXT Series

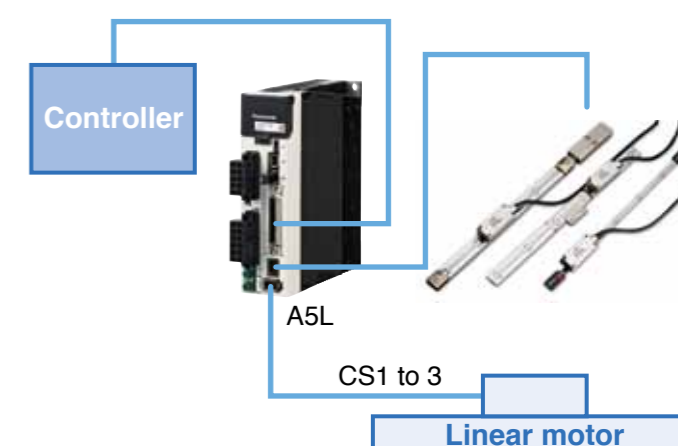

Sales area and Language



Please contact the following address for details.

- Japanese
- English
- Chinese
- Spanish

For more information

URL: <http://www.fagorautomation.com/en/>

Contact: **Fagor Automation, S. Coop.**

Bo San Andrés No19 E-20500 – Arrasate/Mondragón, Spain

[E-mail: Jmviniegra@fagorautomation.es]

TEL: +34-943-719200 FAX: +34-943-791712

Feedback Scale

MI5000si/P / MI6000si/P

Features

Resolution can be multiplied by up to 16384

- Minimal size
- Tape scale compatible (for linear, long axis)
- Glass linear scale compatible (high precision, for X/Y/Z axis)
- Glass rotary scale compatible (for θ axis)



Specification

Item	Description	
	MI5000si/P	MI6000si/P
Sensor size	H: 11.03 mm L: 38.50 mm W: 13.50 mm	H: 8.23 mm L: 22.61 mm W: 12.70 mm
Power supply	5 Vdc \pm 5% @ 172 mA	
Temperature resistance	During operation: 0 °C to 70 °C During storage: -20 °C to 85 °C	
Cable	Double shielding 20 x 10 ⁶ cycles @ 20 mm	
Signal period	20 μ s	
Short range Accuracy	30 nm, with tape scale 20 nm, with glass scale	
Longe range Accuracy	\pm 1.5 μ m up to 130 mm	

Sales area and Language



- English
- Japanese

For more information

URL: <http://www.gsig.co.jp/microe/> (Japanese)

Contact: **GSI Group Japan Corporation Encoder Group** [E-mail: tnakada@gsig.com]
East Square Omori, 6-20-14 Minamioi, Shinagawa-ku, Tokyo 140-0013, Japan Sales Account Manager: Nakada
TEL: +81-3-5735-2464 FAX: +81-3-5753-2467

Feedback Scale

SR70/SR80/SL700/BF1 series

Features

- High speed response with Serial interfaces for MINAS series.
- Direct connection with servo drive (Total cost reduction)
- Excellent durability to harsh environment (Dirt, Oil and Vibration except BF1)
- Absolute scales (SR77/SR87) up to 10 nm resolution with 200 m/min response speed.

Open Type (DIGIRULER)	Slim Type Sealed Scale	Robust Type Sealed Scale	High-resolution Reflective Type (LASERSCALE)
SL700 + PL101RP/RHP (A4NL/A5 family) SL710 + PL101RP/RHP (A4NL/A5 family)	SR77 Series (A4/A4N/A4NL/A5 family) SR75 Series (A4NL/A5 family)	SR87 Series (A4/A4N/A4NL/A5 family) SR85 Series (A4NL/A5 family)	BF1 Series (A5 family)

Specification

Item	Description								
	Open Type (DIGIRULER)				Slim Type Sealed Scale		Robust Type Sealed Scale		High-resolution Reflective Type (LASERSCALE)
Type									
Part No.	SL700 + PL101RP	SL710 + PL101RP	SL700 + PL101RHP	SL710 + PL101RHP	SR77	SR75	SR87	SR85	BF1
Compatible servo drive	A4NL/A5 family				A4/A4N/A4NL/A5 family	A4NL/A5 family	A4/A4N/A4NL/A5 family	A4NL/A5 family	A5 family
Effective length	50 mm to 100000 mm				70 mm to 2040 mm		140 mm to 3040 mm		30 mm to 1400 mm
Accuracy	\pm 10 L μ m (integral number in unit of 1 m when effective length is 3 m or shorter) * When longer than 3 m, consult us.				3+3L/1000 μ m-p or 5+5L/1000 μ m-p * L = Effective length (mm)				\pm 0.5 μ m (30 to 170 mm)/ \pm 1 μ m (220 to 370 mm)/ \pm 3 μ m (420 to 520 mm)/ \pm 5 μ m (570 to 970 mm)/ \pm 10 μ m (1070 to 1400 mm)
Resolution	0.1 μ m				A5 family: 0.01 μ m to 1 μ m A4/A4N/A4NL: 0.05 μ m to 1 μ m				0.001/0.01 μ m
Type	Incremental				Absolute	Incremental	Absolute	Incremental	Incremental
Response speed	10 m/s				3.3 m/s				0.4/1.8 m/s
Output signal	Specific to MINAS series. Serial output								
Origin signal	None	1 point	None	1 point	-	1 point	-	1 point	1 point
Degree of protection	IP50 equivalent		IP67 equivalent		IP54 (without air purge)/IP65 (with air purge)		-		

* High speed, quick response and high reliability are secured through serial communications.

* Conversion cable CK-T185 is required for A5 connection.

Sales area and Language



- Japanese
- German
- English

Please contact the following address for details.

For more information

URL : <http://www.magnescale.com/mgs/language/english/>

Contact: **Magnescale Co., Ltd.** [E-mail: info-mgs-eng@magnescale.com]
To identify local distributors, please contact Magnescale Co., Ltd. International Sales Division Isehara Headquarters
45 Suzukawa, Isehara, Kanagawa 259-1146, Japan TEL: +81-463-92-7971 FAX: +81-463-92-7978

Linear Scale

ABS AT500 series/ST700 series

Features

- Encoders of various types, assembly type, separate type, absolute linear support various applications
- Directly connectable to MINAS series servo drive.
- Provide high resolution and high precision. Assembly configuration is best suited to mechanical processing (AT500 series).
- Electromagnetic induction type is resistant to dirt and its separate construction is best suited to semiconductor and liquid crystal devices (ST700 series).

ABS AT500 series (assembly type)

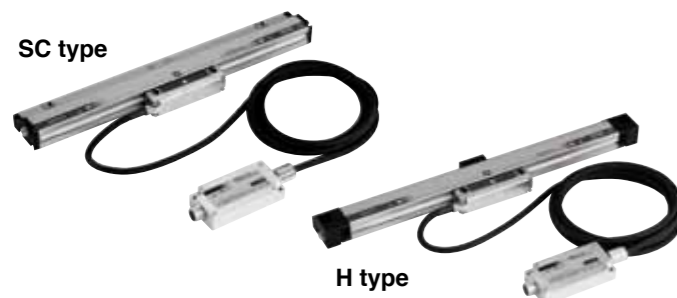

ABS ST700 series (separate type)



Specification

Item	Description		
	ABS AT5000 series		ABS ST7000 series (compact specification)
Detection system	Assembly type absolute scale Combined electrostatic capacity and optical ABS linear encoder		Electromagnetic induction type ABS linear encoder
Part No.	AT573A-SC	AT573A-HC	AT573A-HR/HL
Resolution	0.05 μm		0.1 μm
Max. effective range	100 to 2200 mm	100 to 1000 mm	100 to 350 mm
Detection head size (mm)	—		50 × 28 × 11
Accuracy (μm): 20 °C	3 + 3 L/1000 *	2 + 2 L/1000 *	
Max. response rate	2.5 m/s		5 m/s
Vibration resistance/shock resistance	20 G/35 G	15 G/20 G	
Linear expansivity	(8.5±0.5) × 10 ⁻⁶ /°C		(12±1.5) × 10 ⁻⁶ /°C
Operating temperature/storage temperature range	0 °C to 45 °C/-20 °C to 70 °C		0 °C to 50 °C/-20 °C to 70 °C
Operating humidity/storage humidity range	20 % to 80 %RH (No dewing)		
Power supply	5 V _{DC} ± 5 %		5 V _{DC} ± 10 % <small>(Ripple + spike noise components should be 100 mV or below.)</small>
Max. current consumption	270 mA (MAX)		
Head cable length	2 m (Detection head to interface BOX)		1 m
Signal cable length	3 m		—
Max. cable length	29 m (Including length of head cable)		
Detection head mount	—		1 on the top and 1 on one side

L: Effective range (mm)

Sales area and Language



North America area: **Mitutoyo America Corporation**
965 Corporate Blvd., Aurora, IL 60502, U.S.A.
TEL: +1-630-820-9666 Toll Free No.: +1-888-648-8869

Europe area: **Mitutoyo Europe GmbH**
Borsigstrasse 8-10, 41469 Neuss, GERMANY TEL: +49-2137-102-0

Other area: Please contact the following address for details. Or Please contact Mitutoyo JAPAN.

For more information

URL: <http://www.mitutoyo.co.jp/eng/>

Contact: **Mitutoyo Corporation**

20-1, Sakado 1-Chome, Takatsu-ku, Kawasaki-shi, Kanagawa 213-8533, Japan TEL: +81-44-813-8234

The incremental linear encoder of a magnetic type

SENSOR / PSLH Series, SCALE / PSLG Series

Features

This encoder has achieved an excellent total performance.

- It is high-speed serial communications corresponding to the MINAS series.
- This encoder is strong in the environment of the magnetic noise, oil, and dust.
- A miniaturization and an excellent cost performance are achieved by the internal manufacturing of the MR element.
- Accuracy is improved by an original magnetization pattern.
- It is a tough encoder structure in the extrinsic noise.



Specification

Item	Description
Model number	sensor PSLH040 + scale PSLG040
Output signals	MINAS series serial output
Resolution (R)	0.1 μm
Power supply voltage	4.6 V _{DC} to 5.5 V _{DC}
Power consumption	250 mA max
Gap of detection	0.25 mm ±0.1 mm
Maximum response speed	6 m/sec
IP code	Correspond to IP50
Detection of reference	Correspond up to three places
Position accuracy	±(5+5×L/1000) μm L=Measuring length (mm) at 20 °C
Measuring length (L)	2400 mm MAX
Thermal expansion coefficient	11.0×10 ⁻⁶ / °C
Operating temperature range	0 °C to 50 °C
Preservation temperature range	-15 °C to 70 °C

Another specifications of resolution, the size of the detection head, and the ABZ output, etc. can correspond.

Sales area and Language



Please contact the following address for details.

For more information

URL: <http://www.nidec-sankyo.co.jp/>

Contact: **NIDEC SANKYO CORPORATION**

Tokyo Office, Nidec Tokyo Bldg., 1-20-13, Osaki, Shinagawa-ku, Tokyo 141-0032, Japan

[E-mail: sensor-sales@nidec-sankyo.co.jp]

TEL: +81-3-5740-3006 FAX: +81-3-6843-3123

Optical Absolute Linear Encoder

RESOLUTE™ series

Features

- True absolute encoder
- Resolution (velocity) : 0.1 μm (40 m/s)
: 50 nm (20 m/s)
: 1 nm (0.4 m/s)
- Unique single-track scale eliminates yaw de-phasing problems
- Determines absolute position upon power up
- Range of scales for a variety of applications
- Low SDE for smooth velocity control
- Worldwide subsidiary support network

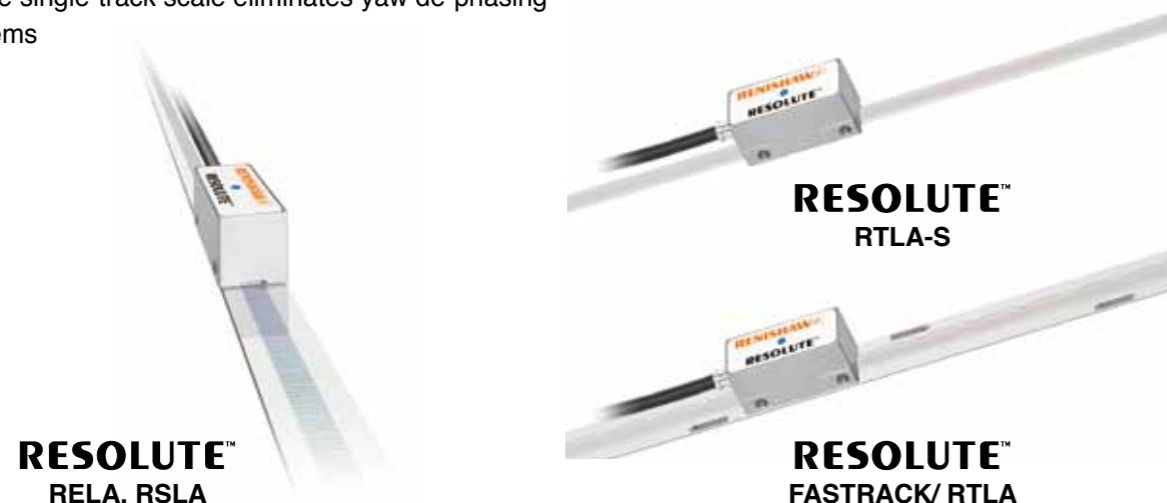

Specification

Series	RESOLUTE™ RELA	RESOLUTE™ RSLA	RESOLUTE™ FASTRACK/RTLA	RESOLUTE™ RTLA-S
Feature	Fine precision and low thermal expansion	The world's most accurate long-length scales	Quick and easy scale replacement	Easiest installation
Scale material	ZeroMet	Stainless steel	Stainless steel tape	Stainless steel tape
Thermal expansion coefficient	~0.6 ppm/°C (0 °C to 30 °C) <1.4 ppm/°C (30 °C to 100 °C)	10.8 ppm/°C	10.6 ppm/°C	10.6 ppm/°C
Scale accuracy	±1 μm	±1.5 μm/m	±5 μm/m	±5 μm/m
Scale length	80 mm to 1130 mm	80 mm to 5000 mm	100 mm to 10000 mm	100 mm to 5000 mm
Scale mounting options	Bonding or Clip/Clamp	Bonding or Clip/Clamp	Track (carrier) mounting	Self-adhesive
Read head size H x L x W	18 mm x 36 mm x 16.5 mm			
Scale size H x W	1.5 mm x 15 mm	1.5 mm x 15 mm	0.4 mm x 18 mm	0.2 mm x 8 mm

Sales area and Language



Please contact the following address for details.

For more information

URL: <http://www.renishaw.jp/> (Japanese)
<http://www.renishaw.com/> (English)

Contact: **Renishaw plc** [E-mail: international@renishaw.com]
New Mills Wotton-under-Edge Gloucestershire GL12 8JR, United Kingdom TEL:+44-1453-524524

Feed back scale selection

Feedback scale table for serial communication

Scale Type	Partner	Series	Resolution* [μm]	Max. rate* [m/s]
Parallel Type (A/B/Z phase)	General	—	Maximum speed after 4x multiplication : 4 Mpps *3	
Serial communication (Absolute)	FAGOR AUTOMATION	SAP / SVAP / GAP	0.05	2.5
		LAP	0.1	2
		SAP10/SVAP10/GAP10	0.01	3
		LAP10	0.01	2
	Magnescale Co., Ltd.	SR77	0.01 to 1	3.3
		SR87	0.01 to 1	3.3
	Mitutoyo Corporation	AT573A	0.05	2.5
		ST778A(L)	0.1	5
	Renishaw plc	RESOLUTE	0.001	0.4
			0.05	20
0.1			40	
Serial communication (Incremental)	GSI Group Japan Corporation.	MI5000si/P MI6000si/P	0.1 (Variable)	5 (Resolution 0.1 μm)
	Magnescale Co., Ltd.	SL700 + PL101RP/RHP	0.1	10
		SL710 + PL101RP/RHP	0.1	10
		SR75	0.01 to 1	3.3
		SR85	0.01 to 1	3.3
		BF1	0.001/0.01	0.4/1.8
	Nidec Sankyo Corporation	PSLH	0.1	6

* Figures under Resolution and maximum rate indicate values specified for A5 family drivers.
These values will be different from those in the feedback scale due to drive maximum pulse frequency limit.

Driver and corresponding feedback scale table

		For Linear Motor control			For Rotary Motor Control		
		A5L	A5NL *4	A4MNL *4	A5/A5II	A5N *4	A5A *4
Maximum Pulse Frequency *1		400 Mpps	400 Mpps	400 Mpps	400 Mpps	400 Mpps	400 Mpps
Serial communication *2	Absolute	○	○	○	○	○	○
	Incremental	○	○	○	○	○	○
A/B/Z phase *3	Incremental	○	○	○	○	○	○

*1 The value of resolution and maximum velocity of feedback scale are limited by maximum pulse frequency of each driver.
*2 For A4 family (A4N, A4NL and A4AL), some feedback scales of serial type cannot be connected. Please contact us for details. For A5 family, all partner's feedback scale of serial type can be connected.
*3 Maximum pulse frequency is up to 4 Mpps (After A/B phase multiplied by 4).
In case of 50 % duty being fine, the value of maximum pulse frequency is available up to 8 Mpps.
*4 Network servo (A5N, A5NL, A5A, A5MNL) has no function to output the A/B/Z regeneration pulse.

AC Servo Actuator SHA-P Series

SHA25P/SHA32P/SHA40P/SHA58P/SHA65P

Features

- The AC servo actuator incorporates the precise control speed reducer (Harmonic Drive® reducer) to the flat AC servo motor.
- The design of the actuator is flat and has hollow shaft structure. Piping, wiring, laser light, etc., can be passed through the through-hole in the center.
- Excellent one way positioning accuracy : 50 sec (0.0139°) with reduction ratio 1/51, and 40 sec (0.0111°) with reduction 1/81 or higher ratio.
- Torque-volume ratio is 5 times or more that of direct drive motor.

Max. torque mapping

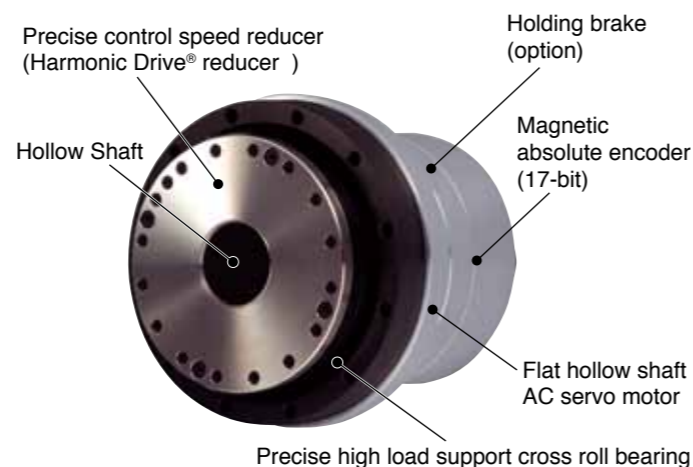
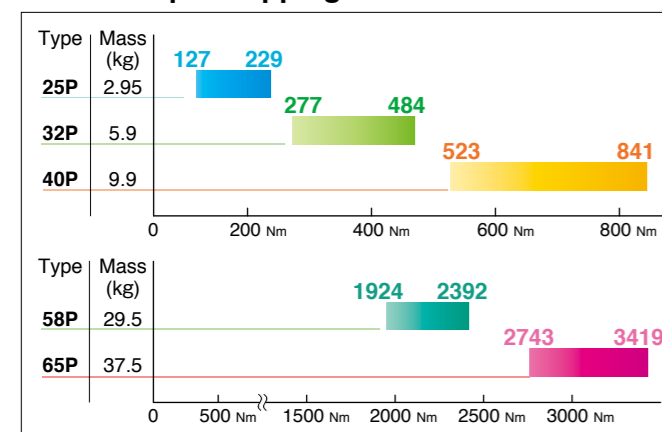

Specification

Item	Model	SHA25P					SHA32P					
		51	81	101	121	161	51	81	101	121	161	
Associated drive		MCDHT3520					MDDHT3530					
Max. torque ^{*2}	Nm	127	178	204	217	229	277	395	433	459	484	
Allowable continuous torque ^{*2,3}	Nm	41	67	81	81	81	92	153	178	178	178	
Max. revolution speed	r/min	109.8	69.1	55.4	46.3	34.8	94.1	59.3	47.5	39.7	29.8	
Max. current ^{*2}	A	8.6	7.5	7.0	6.3	5.2	17.1	15.2	13.5	12.2	9.9	
Allowable continuous current ^{*2,3}	A	3.0	3.0	2.9	2.6	2.1	6.0	6.0	5.7	5.0	4.1	
Moment of Inertia (without brake)	GD ² /4	kg·m ²	0.56	1.42	2.2	3.2	5.6	2.0	5.1	8.0	11	20
Moment of Inertia (with brake)	GD ² /4	kg·m ²	0.66	1.66	2.6	3.7	6.6	2.3	5.9	9.2	13	23
Reduction ratio		1:51	1:81	1:101	1:121	1:161	1:51	1:81	1:101	1:121	1:161	
Allowable moment load	Nm	258					580					
Moment rigidity	Nm/rad	39.2×10 ⁴					100×10 ⁴					
One way positioning accuracy	sec	50	40	40	40	40	50	40	40	40	40	
Encoder		Magnetic absolute encoder										
Output resolution	Pulses/Rev.	6684672	10616832	13238272	15859712	21102592	6684672	10616832	13238272	15859712	21102592	
Mass (without brake)	kg	2.95					5.9					
Mass (with brake)	kg	3.1					6.2					
Mounting direction		Can be installed in any direction.										

*1: Values in the table above represent typical values at output shaft.

*2: Typical values obtained when above associated drives are used (driving with ideal sine wave).

*3: Values obtained at temperature rise saturated with the actuator mounted on the aluminum heatsink shown below.
SHA25P: 350 mm × 350 mm × 18 mm SHA32P: 400 mm × 400 mm × 20 mm

Specification

Item	Model	SHA40P					SHA58P				SHA65P				
		51	81	101	121	161	81	101	121	161	81	101	121	161	
Associated drive		MDDHT5540					MFDHTA390				MFDHTB3A2				
Max. torque ^{*2}	Nm	523	675	738	802	841	1924	2067	2236	2392	2743	2990	3263	3419	
Allowable continuous torque ^{*2,3}	Nm	160	263	330	382	382	714	905	969	969	921	1149	1236	1236	
Max. revolution speed	r/min	78.4	49.4	39.6	33.1	24.8	37.0	29.7	24.8	18.6	34.6	27.7	23.1	17.4	
Max. current ^{*2}	A	26.7	21.8	19.4	17.9	14.6	45.0	39.0	36.0	30.0	62.0	55.0	51.0	41.0	
Allowable continuous current ^{*2,3}	A	9.0	9.0	9.0	8.8	7.2	17.7	17.8	16.4	13.4	22.0	21.9	20.1	16.3	
Moment of Inertia (without brake)	GD ² /4	kg·m ²	5	13	20	28	50	96	149	214	379	110	171	245	433
Moment of Inertia (with brake)	GD ² /4	kg·m ²	6.1	15	24	34	61	106	165	237	420	120	187	268	475
Reduction ratio		1:51	1:81	1:101	1:121	1:161	1:81	1:101	1:121	1:161	1:81	1:101	1:121	1:161	
Allowable moment load	Nm	849					2180				2740				
Moment rigidity	Nm/rad	179 × 10 ⁴					531 × 10 ⁴				741 × 10 ⁴				
One way positioning accuracy	sec	50	40	40	40	40	40	40	40	40	40	40	40	40	
Encoder		Magnetic absolute encoder													
Output resolution	Pulses/Rev.	6684672	10616832	13238272	15859712	21102592	10616832	13238272	15859712	21102592	10616832	13238272	15859712	21102592	
Mass (without brake)	kg	9.9					29.5				37.5				
Mass (with brake)	kg	10.7					32				40				
Mounting direction		Can be installed in any direction.													

*1: Values in the table above represent typical values at output shaft.

*2: Typical values obtained when standard drives are used (driving with ideal sine wave).

*3: Values obtained at temperature rise saturated with the actuator mounted on the aluminum heatsink shown below.
SHA40P: 500 mm × 500 mm × 25 mm SHA58P/SHA65P: 650 mm × 650 mm × 30 mm

Application Sample

URL : Sample applications

<http://www.hds.co.jp/english/products/application/>

Please refer to the sample and typical applications for the SHA-P Series with Panasonic Servo as shown above URL.

Sales area and Language

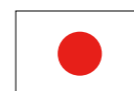

- English
- Japanese

Please contact the following address for details.

For more information

Product URL: <http://www.hds.co.jp/english/>

Contact URL: <https://www.hds.co.jp/english/contact/index.php>

Contact: **Harmonic Drive Systems Inc. Overseas Division**

1856-1 Hotakamaki, Azumino-shi, Nagano, 399-8305, Japan

TEL: +81-263-83-6935 FAX: +82-0236-83-6901